



TT+ TOURING & THEATRE

TT+ SYSTEM SOLUTIONS

ACTIVE AND CONTROLLED

TT+ systems are active and feature highly advanced digital or analogue electronic processing. TT+ high power digital amplifiers offer very low distortion and natural sound with very efficient heat dissipation coupled with low energy consumption.

The integration of precise analogue and digital processing, directly available with simple presets, the possibility of monitoring and controlling the systems with RDnet proprietary protocol brings TT products to unmatched results in the audio industry.



LARGE VENUE SYSTEMS

RCF TT+ large venue systems are a specifically designed group of products dedicated to highly demanding large scale applications. This system is designed to be easily scalable, from a few modules to full size arrays for very large outdoor stadia or public spaces.

THEATRE SYSTEMS

The TT+ series offers a variety of line array systems, speakers and stage monitors that combine compact size and unobtrusive look with outstanding sound definition and power, making them perfect for theatre sound reinforcement.



/ TOURING

The capability of delivering superior SPL output of our systems will reduce the truck space requirements. The higher efficiency of integrated digital amplifiers will reduce the energy requirements and the integrated processing and the cabling reduction will make the set-up faster and easier.

/ STADIA AND ARENAS

Whether the event is a live performance or a sport match, whether the speaker system is a rented solution or a dedicated permanent installation, TT+ will excel for superior vocal intelligibility, dynamic of sound and musical clarity.

New perspective on linearity



FIRPHASE

RCF speakers are designed using a proprietary and advanced FIR filtering technology, conceived to deliver transparent sound, absolute clarity and perfect stereo images to the listener.

The special FIRPHASE filters allow to achieve coherent distribution of sound for all listeners without phase distortions, ensuring minimum latencies to the system.

PHASE MATTERS

The design of the FIR filter for this specific purpose should start from an accurate measurement of the loudspeaker phase.

FIRPHASE algorithm use this measurement and adapt the loudspeaker's phase without touching the amplitude equalization.

The heart of the advanced technique used by FIRPHASE is a recursive method (least squares method) combined with a proprietary algorithm that calculates the best FIR filter coefficients set in according to amplitude and phase constrains.

The algorithm corrects phase and amplitude (if necessary) by taking into account the weak points of the transducers and the resonances or cancellations due to the cabinet of the loudspeaker.

This technique allows a deep control of phase at mid-low frequency with relatively small filters, reaching a higher resolution than that one as theory suggests.

/ CONCERT HALLS

The incredibly low distortion of RCF digital amplifiers, the accuracy and transparency of the reinforcement, the possibility of controlling and monitoring each single speaker make the TT+ the perfect indoor system that will satisfy the most demanding artists, from opera and musicals to symphony and rock.

/ HOUSES OF WORSHIP

From small and medium houses of worship to very large community churches a TT+ system will always deliver unique intelligibility, well defined pattern control, exceptional feedback stability during speech and will immediately be ready to play high definition music and soundtracks at the desired spl level.

TT+ TECHNOLOGY



INNOVATION

Our research and engineering department can offer innovative projects with finite control of each detail, from the loudspeaker voice coil wire to the highly efficient extended dynamic amplifier topology. There are many different ingredients that go into creating quality products and systems. These include computer aided simulation software to assist the understanding of transducer behaviour and amplifier operation and the relationship of dynamics and transient response. RCF utilises over thirty state of the art software packages to identify magnetic circuits, voice coil dynamics, suspension linearity, horn dispersion simulation, crossover filters, amplifier thermal behaviour and more.

INTEGRATION

RCF is one of the few loudspeakers manufacturers worldwide with the ability to completely design and manufacture transducers, speaker systems and amplification and control electronics. Our 60 plus years heritage in audio combined with our state of the art R&D and manufacturing processes, allow us to seamlessly integrate all the ingredients to design and build the TT+ High Definition Touring and Theatre systems.

INTENSITY

The design philosophy for the TT+ Series is based upon offering the sound engineer solutions and tools that are ready to use. Key factors are the ability to sustain very high power with highly efficient sound pressure levels. Intense sound levels are created with extremely high definition and extended dynamic range. Modern construction materials result in mechanical weight ratios that are light for practical flying and portability.

/ WAVES

New horn designs for the entire line. Precision waveguides for the line arrays midrange and compression drivers. Solid aluminium structures for compact two-way systems.

/ STRUCTURES

Baltic birch plywood cabinets. High quality steel mechanical fittings. Aluminium die cast handles. Powder coated grilles. Heavy duty polyurea or epoxy paint finishes on cabinet structures.

From 1949, RCF is committed to the perfect reproduction and amplification of sound. All the products and components are designed and developed internally, to ensure the maximum quality and reliability. RCF have always shared the knowledge, experience, and skills for all the audio professionals. The solid know-how and the continuous technological innovation makes RCF a fundamental reference for all the audio professionals and enthusiasts.

For over six decades RCF professional woofers have represented the ultimate performance, the highest power handling and the most advanced technology. Thanks to high energy magnetic designs, complex cooling systems and specifically developed new technologies, our neodymium transducers put themselves at the same, unsurpassed level. Technology and craftsmanship: every professional compression driver and woofer is precision built in our factory in Reggio Emilia, Italy, using the most advanced moulding and assembly technologies and our experienced dedication and attention. TT+ large venues products offer ready to use solutions and tools in true active high power, high definition touring systems.



/ POWER AND CONTROL

Powerful switching power supplies. Low distortion and natural Class D amplifiers. Huge energy reserve in capacitor buses.

Unique audio quality from an RCF exclusive premium analogue input board. Maximum flexibility and control from a newly designed 96 kHz, 32 bit floating point DSP.

/ INTEGRITY

Advanced designs. High quality materials. Precise manufacturing. Precision assembly. Extensive quality control procedures. RCF's solid audio heritage.

55

TTL 55-A

ACTIVE THREE-WAY LINE ARRAY MODULE

The TTL 55-A is a high power, three way, active line array module engineered to deliver an incredible output for use in indoor and outdoor large spaces. The system is designed to be easily scalable from few modules for medium and small theatres to full size arrays for very large outdoor stadia and public spaces.

The three new designs for the six neodymium transducers that power the system represent the result of many years dedicated to pioneering new solutions using the best materials available on the market.

THE BEST VOCAL CLARITY FROM A LARGE LINE ARRAY

The TTL 55-A midrange transducer features a unique "Impedance Control Coil" technology. A secondary coil wound on the speaker yoke and driven in opposite phase to the primary coil has the function of cancelling the primary coil inductance, increasing the speaker sensitivity and reducing the speaker distortion. A primary effect of this technology is the improvement of the temporal behaviour of the speaker, improving the crossover transition from the midrange to the compression drivers.



The TTS 56-A is the powerful choice for the large format TTL 55-A line array systems.

The TTS 36-A is the preferred choice for more compact systems.

For theatrical applications or as a bass complement for very large systems the TTL 36-AS is the solution.



COMPRESSION DRIVERS

- 3 x 1.5" throat neo compression drivers, 2.5" voice coil
- Very compact diameter design



WOOFERS

- 2 x 12" high power vented neo woofers, 4" voice coil
- Minimum weight basket design



MIDRANGE

- 10" Very high BL neo midrange, 3.5" voice coil
- Aluminium sealed basket design



**RDNET
ON BOARD**

p.n. 130.00.188 (220-240V) - p.n. 130.00.189 (115V)

- 143 dB SPL Max
- 3500 W 4-way class-D amplification
- 2 x 12" high power neodymium woofers, 4" v.c.
- 10" neodymium midrange, 3.5" v. c.
- 3 x 1.5" neodymium compression drivers, 2.5" v. c.
- **FiRPHASE**
- 96 kHz, 32 bit DSP processing
- Tour grade Baltic birch cabinet and mechanics



INSIDE VIEW

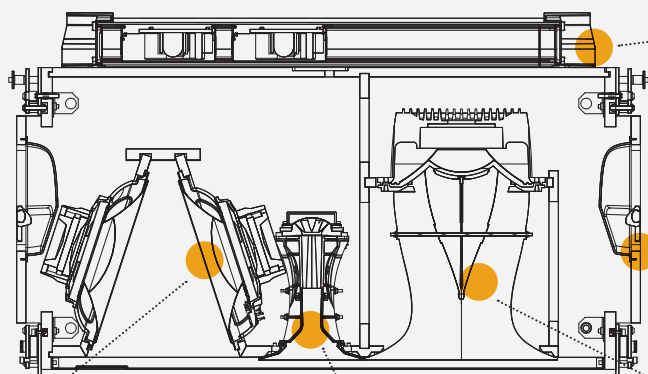

/ POWER PLATFORM

The power section comprises 4 high power digital amplifiers, a state of the art 32 bit floating point DSP processing, network board, high quality analog inputs.

/ TOURING GRADE CABINET

The cabinet is in Baltic birch and the mechanics are laser cut in high grade steel. The weight of the system is less than many similar size passive competitors.

/ LF CLAM SHELL CONFIGURATION

The 2 woofers, in a band-pass loading configuration, provide a very tight and powerful bass response. The acoustical configuration is very efficient in the 100 Hz region and free from dual source cancellations.

/ HF ARRAY

The high frequency section employs three high power 2,5" voice coil compression drivers housed on a very compact slotted horn. Precision assembled titanium domes to produce very high power and clarity.

/ HORN LOADED MF

The 10" midrange is a state of the art neodymium design. It features a sealed aluminium basket, incredibly high BL product, a secondary "distortion reduction" coil. The transducer is loaded on a 4-slot constant directivity horn that guarantees a uniform vertical coupling module to module.



"distortion reduction" coil

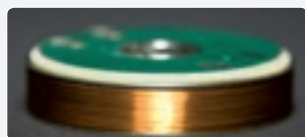

The TTL 55-A amplifier represents a state of the art execution of a DSP controlled multi-way digital amplification. The analog input board offers xlr input and output link, cluster size control switches, high frequencies correction switches, pre-loaded equalization by-pass switch.

The signal processor is a 32 bit floating point DSP. The DSP takes care of crossovers, equalisations, soft-limiters, rms limiters, large signal compression and customised presets for the 4 way amplification.



**TEC AWARD
NOMINATION**

36

TTL 36-AS

ACTIVE LINE ARRAY SUBWOOFER MODULE

The TTL 36-AS is the ideal flyable bass complement for the TTL 55-A array system. The clam-shell design guarantees the maximum output per size while the 2 x 4.5" voice coil vented 18" woofer design offers the minimum of power compression. The TTL 36-AS is perfect to create flown systems for theatrical and indoor requirements. For very large outdoor systems it is the perfect complement to reinforce the TTL 55-A bass performance in combination with the ultra powerful TTS 56-A subwoofers.

The integrated mechanics provide perfect compatibility with the TTL 55-A line array module.

The TTL 36-AS subwoofer can be rigged on top of the TTL 55-A using the same fly-bar or on the side of the TTL 55-A cluster on a separate fly-bar.

The TTL 55-A and the TTL 36-AS are equipped with a dedicated networking board. Using our proprietary RNet protocol it is possible to monitor all the system parameters, from the input to the status of each single amplifier. Having DSP on board each cabinet, it is possible to address single cabinets or groups of cabinets' specific presets or modifications of parameters like gain, equalisation or delay.

The RNet protocol is based on RS-485 communication protocol, it is very stable and it is possible to send and receive data on a simple XLR cable.



**RNET
ON BOARD**

p.n. 130.00.271 (90-240V)

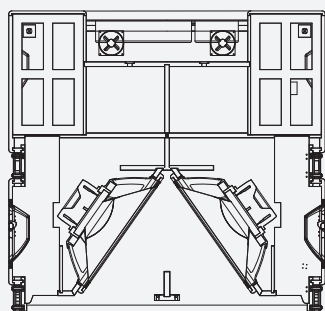

VIRTUAL TILT AND CURVATURE

Taking advantage of the DSP power available on every cabinet it is possible, through RNet, to apply variable delays to single cabinets and create virtual tilting and curvature of TTL 36-AS subwoofer clusters.

- 142 dB SPL Max
- 4000 W (2 x 2000 W digital switching amplifiers)
- 2 x 18" high power neodymium woofer, 4.5" v. c.
- 96 kHz, 32 bit DSP processing
- RNet ON BOARD
- Time delay alignment
- Cardioid preset for stacking groups of 3
- Tour grade Baltic birch cabinet, integrated rigging
- Maximum output per size



/ SIDE HANDLE

The TTL 55-A cabinet features a newly designed die-cast side handle with rubber hand-grip. Thanks to the internal scoop design it is possible to use the handle in three different directions.



/ FRONT MECHANICS

All the mechanical structure is built in high strength structural steel. This special steel thanks to a quenching and tempering process guarantees a yielding strength almost 4 times higher compared to commercial grade steel and maintains the mechanical properties down to -40° C. Thanks to this material the mechanics have high safety factor with a weight under control.



/ REAR MECHANICS AND ANGLES

The TTL 55-A cabinet features 8 possible splay angles, from 0° to 7° with 1° step increment to create curved spiral arrays with very high precision.



/ AMPLIFIER MECHANICAL STRUCTURE

The electronic processing and the amplifier are housed in a solid aluminium extrusion. The housing is tightly fitted to the rear of the cabinet and sealed. The power input and all the signal connectors are housed in two recessed and protected panels.

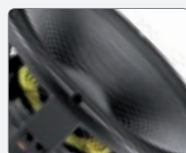

WOOFERS

- 2 x 18" high power vented neo woofers, 4.5" voice coil
- Minimum weight design



The power section comprises 2 x 2000 W digital amplifiers, a state of the art 32 bit floating point DSP processing, time delay setting, network board, high quality analog inputs.

“ TTL 55-A and TTL 36-AS: perfect match in stacking configuration ”

33

TTL 33-A II

ACTIVE THREE-WAY LINE ARRAY MODULE

The TTL 33-A II offers the highest performance from a small size 3 way line array. The incredible high output and dynamics, the extreme accuracy and high frequency extension, plus compact size, make the TTL 33-A II the ideal tool for reinforcing mid-large size outdoor and indoor live performance and events.

Advanced technologies, knowledge, experience, continuous engineering effort and dedication combined to bring these unique results: the TTL 33-A II.

Active, ultra compact, wide dispersion, line array module that set a new standard in touring and theatre sound reinforcement.



The
**READERS'
CHOICE
AWARDS**

WINNER



RELIABLE MECHANICS

Laser cut high quality steel bars and precision machining for easy to use and reliable mechanics. Thanks to the very light weight of the cabinet building the cluster is very simple, fast and effortless.



DIGITAL PROCESSING

The integrated digital processor is based on a state of the art 32 bit, floating point DSP running at 96 kHz sampling rate. The calculation capacity largely exceeds the processing needs and the DSP is never pushed to the limit. Crossover and equalisation of the transducers, limiter, system presets: high pass, air absorption and cluster size corrections.



RD NET INPUT BOARD

The TTL 33-A II is equipped with a dedicated networking board. Using our proprietary RDNet protocol it is possible to monitor all the system parameters, from the input to the status of each single amplifier.

p.n. 130.00.360 (220-240V) - p.n. 130.00.361 (115V)

- 135 dB SPL Max
- 1250 W digital switching amplifiers
- Wide, constant directivity, coverage angle
- 2 x 8" high power neodymium woofers, 2.5" v. c.
- 8" neodymium midrange, 2.5" v. c.
- 3 x 1" neodymium compression drivers, 1.5" v. c.
- High quality analog input board
- 96 kHz, 32 bit DSP processing
- **FiRPHASE**
- Soft limiter and RMS protection



INSIDE VIEW

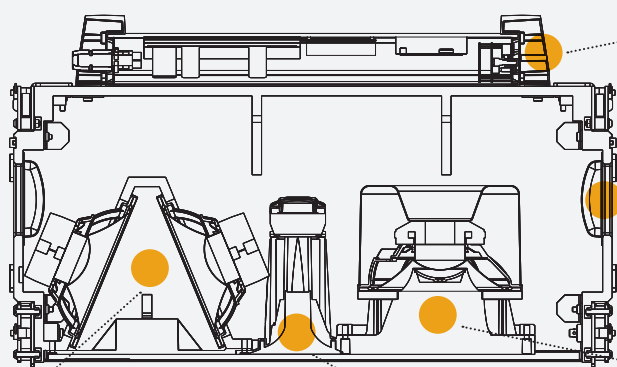

/ POWER PLATFORM

The TTL 33-A II is powered by a 1250 W switching power supply and 3 digital amplifiers: 500 W mid-bass, 500 W midrange and 250 W compression driver. The result is very high output, extremely low distortion and natural sound.

/ TOURING GRADE CABINET

The cabinet is in high quality Baltic birch plywood and the mechanics are laser cut in high grade steel. The weight of the system is less than many similar size passive competitors.

/ CONTROLLED MID-BASS

Light and reliable neodymium 8", in a band pass loading configuration, provides a tight and loud mid-bass. Thanks to a careful acoustic design the sensitivity in the 100 Hz region is almost double that of a typical, similar size, design.

/ COMPRESSION DRIVERS

A new compression driver has been developed for array applications. The best ratio between the size of the diaphragm and the overall diameter and the very small total size makes the ND1411-MT a unique driver for application in line on straight horns.

/ HIGH OUTPUT MIDRANGE

A fast and accurate horn loaded 8" takes care of the midrange frequencies in TTL 33-A II. Powerful neodymium magnet, aluminium die cast basket, aluminium back can in direct contact to the rear plate for best heat dissipation.



**RDNET
ON BOARD**



SUGGESTED SUBWOOFERS

- TTS 56-A / TTS 36-A

TTL 6-A

ACTIVE THREE-WAY LINE ARRAY MODULE

The TTL 6-A is a high power, three way, active line source engineered to deliver high fidelity output for use indoors and outdoors, for medium to large spaces. TTL 6-A provides all the advantages of line array technology, such as high direct sound, increased range and a uniform level distribution, with additional ease of use. It is the preferred sound set-up for stacked systems and when a wider dispersion is required.

The 3-way TTL 6-A line source is equipped with 2 x 12" low frequency woofers, 4 x 6.5" midrange and a 3.0" voice coil compression driver with wave-guide for distinctive homogenous directivity. The integration of four channels of digital amplification and the advanced digital processing set a new standard for distortion, noise and thermal efficiency.



UNIQUE HORN DESIGN

The vertically asymmetrical horn design accurately projects the sound energy and avoids unwanted rejections. This horn design allows two TTL 6-A perfectly cascading for an excellent control of directional characteristics. In difficult acoustic environments intelligibility is significantly increased.



WEATHER RESISTANT CABINET

The cabinet is made of high-quality Baltic birch plywood with every layer glued with a special adhesive. This makes the cabinet completely weather resistant even before the painting process. Our in-house paint department uses a special polyurea paint to create a full cabinet coating, making it highly resistant to scratches and bumps. The cabinet features four die-cast powder-coated aluminum side handles with rubber handgrips.

TTL6-A ADVANTAGES

- 3-way active line source
- Symmetrical acoustic design
- Wide and constant dispersion
- Vertically scalable
- Easy to stack and fly
- Vertically asymmetrical waveguide



RDNET ON BOARD

p.n. 130.00.475 (220-240V) - p.n. 130.00.476 (115V)

- 139 dB max SPL
- 4 x Class D amplifier, 2200 W total power
- Premium-quality DSP with optimized phase response
- 1.4" neo compression driver, 3.0" v.c. with a waveguide
- 4 x 6.0" neo midranges
- 2 x 12" neo woofer
- 90°x 30° directivity (+5°, -25°)
- RDNet remote monitoring and control
- Maximum output, perfect audio fidelity
- Four grade cabinet and mechanics

TTL 6-AS

ACTIVE LINE ARRAY BASS MODULE

The TTL 6-AS is a high power, active line source bass module engineered to deliver high output for use indoors and outdoors, for medium to large spaces. TTL 6-AS is the companion bass module for the TTL 6-A, extending the frequency range of the flown system and improving the bass overall output. The TTL 6-AS bass module is equipped with 3 x 12" low frequency woofers in bass reflex configuration. The integration of three channels of digital amplification and the advanced digital processing set a new standard for distortion, noise and thermal efficiency.



INCREDIBLE EFFICIENCY

Thanks to the incredible efficiency of our amplifiers no fans are needed for silent operation of the speaker. A 32-bit, floating point DSP manages:

- Programmable system equalisation
- Input sensitivity reduction
- Soft limiter and gentle compressor for very high signal inputs
- RMS current monitoring and transducer protection.



The heavily braced internal structure survives long-term use and transportation and all the parts features metal inserts with metric screws. On top and bottom of the cabinet two large metal brackets are integrated in the cabinet for safe rigging day after day.

p.n. 130.00.500 (90-240V)



**RDNET
ON BOARD**

- 139 dB max SPL
- 3 x Class D amplifier, 1650 W total power
- Premium-quality DSP with optimized phase response
- 3 x 12" neodymium woofer
- RDNet remote and control
- Maximum output, perfect audio fidelity
- Tour grade cabinet and mechanics

P5

TTP 5-A

POINT SOURCE ARRAY

The TTP 5-A is a high power, two way, active array module engineered to deliver high fidelity output for use in indoor and outdoor medium and large spaces. The system is designed to create horizontal or vertical arrays with a constant curvature. The RCF Precision newly designed 4" compression driver loaded on a dedicated waveguide guarantees the exceptional sound projection and pattern control. The new woofer design represents the result of many dedicated years in developing new solutions using the best materials available on the market. The integration of two channels 1600 Watt digital amplification and the advanced digital processing set a new standard for distortion, noise and thermal efficiency.

FULLY FEATURED INPUT BOARD

TTP 5-A, TT 5-A, TT 2-A AND TT 1-A are equipped with a state of the art input board which features:

- XLR In/Out
- Gain reduction
- Time Delay
- Speaker presets
- RDNet ready option
- RDNet bypass switch
- 4 status LEDs
- Powercon In/Out

ACTIVE SYSTEMS

The new TT+ Two-Way Systems are equipped with class D power amplifiers controlled from 32 bit floating point DSPs. All the amplifiers are housed in a separate chamber to be insulated from vibrations.

4.0" TITANIUM DOME NEO C. DRIVER

Technology and craftsmanship: every professional compression driver and woofer is precision built in our factory in Reggio Emilia, Italy, using the most advanced moulding and assembly technologies and our experienced dedication and accuracy.



p.n. 130.00.380 (220-240V) - p.n. 130.00.384 (115V)

- 138 dB max SPL
- 1600 W, 2 way amplification
- 15" neo woofer, 4.0" v. c.
- 2.0" titanium dome neo c. driver, 4.0" v. c.
- 22.5° x 60° precision waveguide
- 96 kHz, 32 bit DSP processing
- Maximum output, perfect audio fidelity
- Tour grade cabinet and mechanics
- RDNet remote monitoring and control





15" NEO WOOFER

The high power 15" neodymium woofer with a 4" voice coil guarantees a very controlled and precise bass response perfect for indoor applications such as theatres. A fully optimised T-pole design generates the minimum amount of flux modulation, the unique dual-forced air venting system guarantees a very efficient voice coil ventilation for minimum power compression and higher power handling.



MULTIFUNCTIONAL HANDLES

The TTP 5-A features comfortable side and top handles in rubber coated aluminium to provide an easy transport and positioning.



TOUR GRADE CABINET

The TTP 5-A cabinet is made of marine baltic birch plywood coated with heavy duty polyurea finish. The structure is heavily braced and all the fittings are designed to fulfil the requirements of a long touring life.



QUICK LOCKING

The TTP 5-A features integrates mechanics with quick looking pins. The pin insertion can be both frontal or lateral for easy assembling of both horizontal or vertical arrays.



**RDNET
ON BOARD**



MODULAR SYSTEM

The TTP 5-A is a flexible modular system, easily array-able depending on the size of the event and the required coverage.

High quality mechanics with a smart locking system make the set up of the system fast and effortless.

*“ Perfect vocal reproduction
from 4.0” compression driver „*

5 TT 5-A

ACTIVE HIGH OUTPUT TWO-WAY SPEAKER

Thanks to the powerful 4" compression driver, the large sized horn, the incredibly fast woofer, TT 5-A offers the highest performance from a wide dispersion, active, 2 way system. High output and dynamics, extreme linearity and fidelity makes the TT 5-A a unique product in its category. The TT 5-A is the ideal professional two-way speaker for mid field and near field sound reinforcement, live performance and events. The RCF Precision newly designed 4" compression driver guarantees the exceptional sound projection and pattern control. The integration of the 1600 Watt, digital amplification and the advanced digital processing set a new standard for distortion, noise and thermal efficiency. The speaker is equipped with a complete set of integrated rigging mechanics for rental or installation.



*“ High output and dynamics,
extreme linearity and fidelity ”*

TT 5-A is the result of an incredibly advanced acoustic design, state of the art digital power amplifiers and a group of innovative processing algorithms that take care of the speaker linearity and its dynamic control.

The TT 5-A is a high power, active loudspeaker designed specifically for high quality indoor and outdoor near and mid field sound amplification.

It is equipped with 1600 W digital amplification, 1100 W are delivered from the low frequencies amplifier and 500 W from the high frequency digital module.

The low frequency transducer is a powerful 15" hypervented woofer with 4" voice coil.

A large sized 2" titanium dome compression driver loaded to a 90°x 50° dispersion constant directivity horn provides a perfect high frequency coverage.

UNLIMITED POWER

TT 5-A features a newly designed class D amplifier delivering 1100 Watt for low frequencies and 500 Watt for high frequencies.

p.n. 130.00.379 (220-240V) - p.n. 130.00.383 (115V)

- 136 dB max SPL
- 1600 W, 2 way amplification
- 15" neo woofer, 4.0" v. c.
- 2.0" titanium dome neo c. driver, 4.0" v. c.
- 90° x 50° precision waveguide
- 96 kHz, 32 bit DSP processing
- Maximum output, perfect audio fidelity
- Tour grade cabinet and mechanics
- RDNNet READY



MAXIMUM FLEXIBILITY

The TT 5-A is the perfect tool for theatrical installations, front and side fills, and distributed sound systems.



POLE MOUNT

A rugged powder coated steel pole mount has been installed on the bottom of the TT 5-A to provide a pole mount option.



REAR PANEL

The rear panel features a simple rotary encoder to control all the speaker functions. A bright 7 segment display clearly helps the system setting. The only switch on the panel sets the local or remote control. A simple command from RDNet totally disables the input panel.



REAR ENCODER CONTROL

Pushing the rear encoder it is possible to select the following three functions:

- input gain reduction
- speaker delay setting
- selection of a speaker preset



**RDNET
READY**

With the RDNet protocol it is possible to monitor all the system parameters, from the input status of each single amplifier.

Thanks to the integrated DSP board on each unit, it is possible to address the single cabinets or groups of cabinets' specific presets via the RDNet GUI software as well as to modify parameters like gain, equalisation and delay.



TT 2-A

ACTIVE HIGH OUTPUT TWO-WAY SPEAKER

The TT 2-A is the most flexible and powerful tool in its class. The incredible output and dynamics, the extreme linearity and fidelity makes the TT 2-A a special product in its category. The TT 2-A is the ideal compact two-way speaker for near field sound reinforcement, live sound and corporate events. The integration of the 1600 Watt, two channel, digital amplification and the advanced digital processing set a new standard for distortion, noise and thermal efficiency. The speaker is equipped with a complete set of integrated rigging mechanics for rental or installation. Dedicated accessories to create clusters are available.

A 32 bit, floating point DSP is taking care of:

- 2 way system crossover and transducers alignments
- 8 programmable system equalisation
- Programmable output time delay
- Input Sensitivity reduction
- Soft limiter and gentle compressor for very high signal inputs
- Rms current monitoring and transducers protection
- Input noise reduction

A specially developed algorithm takes care of the frequency dependent soft limiter offering to the listener the same linearity of the system from very low level signals to the maximum amplifier output.



p.n. 130.00.378 (220-240V) - 130.00.382 (115V)

- 134 dB max SPL
- 1600 W, 2 way amplification
- 12" neo woofer, 4.0" v. c.
- 2" titanium dome neo c. driver, 3.0" v. c.
- 90° x 50° precision waveguide
- 96 kHz, 32 bit DSP processing
- Maximum output, perfect audio fidelity
- Tour grade cabinet and mechanics
- RDNNet READY



OPTIONAL RDNET INPUT BOARD

A dedicated processing area is available through the optional RDNet input board. Remote monitoring, special custom equalisations, high and low pass, single way solo and mute, and many other options. All available on RDNet.



POLE MOUNT

A rugged powder coated steel pole mount has been installed on bottom of the TT 2-A to provide a pole mount option.



REAR ENCODER CONTROL

Every model is equipped with a rear encoder making possible the selection of:

- input gain reduction
- speaker time delay
- selection of eight speaker presets dedicated to Close, Linear and Far listening



DIE-CAST HANDLES

The cabinet features two newly designed die-cast aluminium side handles powder coated and with rubber hand-grip. Thanks to the internal scoop design it is possible to use the handle in three different directions to facilitate the transport, positioning and loading operations.



**RDNET
READY**

/ THE REAR PANEL

The rear panel features a simple rotary encoder to control all the speaker functions. A bright 7 segment display clearly help the system setting. The only switch on the panel sets the local or remote control. A simple command from RDNet totally disables the input panel.

1 TT 1-A

ACTIVE HIGH OUTPUT TWO-WAY SPEAKER

Hi-fi acoustic design, superb deep bass punch, very linear and precise frequency response. The TT 1-A is the perfect small and powerful speaker for almost any sound reinforcement situation — ideal for live sound situations, incredible for playback and monitoring. The TT 1-A, unique in its category, features a neodymium 3,0" voice coil compression driver on a large, constant directivity, precision horn. The integration of the 800 Watt, two channel, digital amplification and the advanced digital processing set a new standard for distortion, noise and thermal efficiency. The speaker is equipped with a complete set of integrated rigging mechanics for rental or installation. Dedicated accessories to create clusters are available.

TT+ two-way speakers are the result of decades of experience in the RCF laboratories. They have become a byword in the touring business for sound quality, dynamic range and system features. Their cabinet construction, portability and installation solutions set new standards for professionals and the TT1-A falls into that category.



CLASS D DIGITAL AMPS

Two independent Class D digital amplifiers, characterised by high efficiency, hi- sound, extremely low distortion with negligible quiescent noise and stable burst response, make the TT+ speakers the most powerful two-way cabinets in their category. The amp modules are housed in a separate chamber and are mechanical insulated from the cabinet vibration. Specially developed algorithms enhance the linearity of the system from very low level signals to maximum amplifier output.



p.n. 130.00.377 (220-240V) - 130.00.381 (115V)

- 131 dB max SPL
- 800 W, 2 way amplification
- 10" neo woofer, 3.0" v. c.
- 2" titanium dome neo c. driver, 3.0" v. c.
- 90° x 60° precision waveguide
- 96 kHz, 32 bit DSP processing
- **FiRPHASE**
- Maximum output, perfect audio fidelity
- Tour grade cabinet and mechanics
- RDNNet READY



CUSTOM MADE TRANSDUCERS

For the TT+ series new state-of-the-art RCF transducers were specifically developed and new horn designs guarantee a uniform pattern coverage and perfect loading to the lowest frequencies. The compression drivers feature high performance 3-inch and 4-inch diaphragms; RCF has finalised an oxygen free process of moulding pure titanium ultra thin films in high quality finely controlled shaped diaphragms.

The strong neodymium magnetic structure of the mid-bass transducers guarantees dynamism and precision, and the unique Dual-forced venting offers a very efficient voice coil ventilation, minimising the power compression.

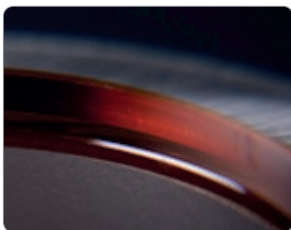

VOICE COIL ASSEMBLY

The voice coil assembly is designed using a high strength, high temperature Kapton voice coil former, rectangular profile copper clad aluminium wire and assembled using advanced, specially formulated adhesives. Proprietary curing processes ensure optimal assembly strength and safe operation even under extreme thermal conditions. The top of the former is bent and bonded directly to the edge of the titanium diaphragm resulting in a Direct Drive™ configuration, which guarantees optimal transfer of energy between the voice coil and the dome assembly.



**RDNET
READY**



The speaker offers many rigging possibilities:

- Top M20 insert
- Pole Mount on the bottom
- Top and bottom fly tracks (6x)
- Side quick lock pins (4x)
- Side M10 rigging points (4x)



The paint department inside our factory in Italy utilizes a special polyurea paint to create a very thick full coating of the cabinet making it highly resistant to scratches and bumps.



25

TT 25-A II



ACTIVE HIGH DEFINITION TWO-WAY SPEAKER

The TT 25-A II is the most flexible and powerful tool in its class. TT 25-A II offers very high output and dynamics, and extreme linearity and accuracy in a compact size. TT 25-A II is a 2-way active system featuring 15" neo woofer, 86 mm voice coil in a bass reflex configuration; 1,5" exit, 75 mm voice coil neo compression driver; 90° x 60° constant directivity horn, 90° rotatable. The TT 25-A II is the ideal professional speaker for sound reinforcement, live performances and events.



*“ the most flexible
and powerful tool in its class ”*



SPEAKER FUNCTION CONTROL

The rear panel features a simple rotary encoder to control all the speaker functions. A bright 7 segment display clearly help the system setting. The only switch on the panel sets the local or remote control. A simple command from RDNet totally disable the input panel.



RIGGING POSSIBILITIES

- Top M20 insert
- Pole Mount on the bottom
- Top on bottom fly tracks (6x)
- Side quick lock pins (4x)
- Side M10 rigging points (4x)



**RDNET
ON BOARD**

p.n. 130.00.446 (220-240V) - 130.00.447 (115V)

- 134 dB max SPL
- 1100 W Class D Amplifier
- 90 x 60 constant directivity coverage angle
- 15" neo woofer, 3.5" v.c.
- 1.5" neo c. driver, 4.0"v.c.
- **FIRPHASE**
- RDNet remote monitoring and control
- Multifunctional cabinet
- Very high output

TT 22-A II

ACTIVE HIGH DEFINITION TWO-WAY SPEAKER

TT 22-A II is a 2-way active system featuring 12" neodymium woofer, 86 mm voice coil in a bass reflex configuration and a 1,4" exit, 75 mm voice coil neo compression driver. An extremely careful acoustic design plus the highest quality transducers and a powerful amplifier make the TT 22-A II speaker system the perfect solution from live sound situations to playback and monitoring. The amplifier section features 1100 W power, 800 W low frequency, 300 W high frequency. The cabinet is made of marine baltic birch plywood and features high resistance polyurea coating. The cabinets features 2 side handles, 6 x fly-track rigging points, quick lock pin receptacles and a steel pole mount.



NEW WOOFER DESIGN

The TT 22-A II new woofer features an extremely fast and accurate bass response and a natural and neutral mid-range response.



CABINET FEATURES

- Two newly designed side handles with rubber hand-grip.
- Quick Lock pin receptacles.



“extremely careful acoustic design plus the highest quality transducers”

The design philosophy for the new TT+ series is based upon offering the sound engineer solutions and tools that are ready to use. Key factors are the ability to sustain very high power with highly efficient sound pressure levels. Intense sound levels are created with extremely high definition and extended dynamic range. Modern construction materials result in mechanical weight ratios that are light for practical flying and portability.



RDNET ON BOARD

p.n. 130.00.444 (220-240V) - 130.00.445 (115V)

- 131 dB max SPL
- 1100 W Class D Amplifier
- 90 x 60 constant directivity coverage angle
- 12" neo woofer, 3.5" v.c.
- 1.5" neo c. driver, 3.0" v.c.
- **FiRPHASE**
- RDNet remote monitoring and control
- Multifunctional cabinet
- Very high output

45

TT 45-CXA



ACTIVE HIGH-OUTPUT STAGE MONITOR

The TT 45-CXA is a full range, high performance symmetrical monitor. The linear curve response, the consistent coverage and acoustic output make the TT 45-CXA the professional choice for medium and large stages. The voicing is accurate and deep, the sound transparent in the mids and extremely accurate at very high frequencies. The size is compact and the profile low for a discrete appearance. The TT 45-CXA is a full range, high power active system that sets a new standard in the touring and theatre sound reinforcement. By producing flat amplitude and phase response, full-range bandwidth and exceptional impulse response, the TT 45-CXA far exceeds the capabilities of conventional stage monitors.



DIGITAL AMPLIFICATION

The TT 45-CXA is equipped with a 2200 W RMS digital amplifier - 1100 W for the HF and 1100 W for the LF. The RDNet input includes remote monitoring, special custom-made equalizations like high pass, dual monitoring, two-way position, high frequency distance correction and many others. A dedicated processing area and a full range of options are available.



COMPRESSION DRIVER

The ultra-compact compression driver with 1.4" exit throat ensures high power handling and superior performance. The 4.0" voice coil is assembled using the RCF's proprietary Direct Drive technology and provides exceptional sound pressure levels, making the TT 45-CXA the right choice for large-scale applications.

TOURING GRADE CABINET

The TT 45-CXA is made of Baltic birch plywood and protected with a premium textured polyurea coating. A stronger loudspeaker's structure results from the use of the most advanced and waterproof adhesives. Finally, low-profile rubber feet and two recessed side handles guarantee a safe positioning.

INSIDE VIEW

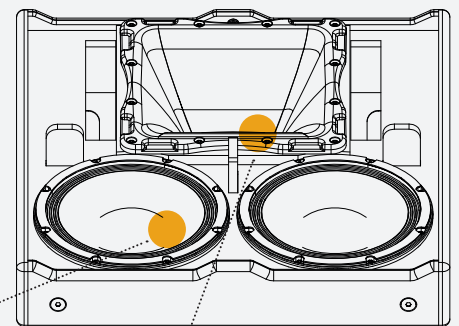

/ LOW FREQUENCIES

The loudspeaker's low frequency section comprises two 10" high-power neodymium woofers in symmetrical configuration.

/ HIGH FREQUENCIES

The high frequency section features a 50° x 90° horn-loaded compression driver with constant directivity coverage angle.



**RDNET
ON BOARD**

p.n. 130.00.506 (220-240V) - 130.00.507 (115V)



- 136 dB max SPL
- 2200 W, three-way class D amplifier
- 50° x 90° constant directivity coverage
- 2 x 10" neodymium woofers, 3.0" v.c.
- Horn loaded 1.4" neo compression driver, 4.0" v.c.
- Symmetrical design
- Multifunctional cabinet
- **FiRPHASE**
- RDNet remote monitoring and control
- Very high output

25 TT 25-CXA

ACTIVE HIGH DEFINITION COAXIAL MONITOR

The TT 25-CXA is a full range, high performance coaxial monitor. The linear curve response, the consistent coverage and acoustic output make the TT 25-CXA II the professional choice for most demanding situations. The voicing is accurate and deep, the sound transparent in the mids and extremely accurate at very high frequencies. The size is compact and the profile very low for a discrete appearance. The TT 25-CXA is a full range, high power active system that sets a new standard in the touring and theatre sound reinforcement. By producing flat amplitude and phase response, full-range bandwidth and exceptional impulse response, the TT 25-CXA far exceeds the capabilities of conventional stage monitors.



CONSISTENT BEAM WIDTH

The beam width remains consistent across the horn's operating frequency range and coverage (60°conical) allows the performer great freedom of movement within the coverage area.



**RDNET
ON BOARD**



CABINET CONSTRUCTION

The cabinet is made of marine Baltic birch plywood and features high resistance polyurea coating. The cabinets features one aluminium top handle and a side pole mount.

INSIDE VIEW

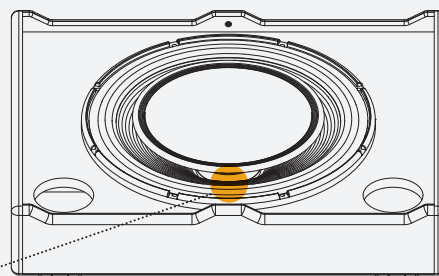

/ LOUDSPEAKER COMPONENTS

The TT 25-CXA II horn on a coaxial transducer exhibits constant Q. Frequency response is uniform across the specified beam width, with minimal side lobes. The compact, active, TT 25-CXA enclosure houses a coaxial 15-inch neodymium cone driver and a 64 mm diaphragm compression driver along with phase-corrected control electronics and amplification.

p.n. 130.00.448 (220-240V) - 130.00.449 (115V)

- 136 dB max SPL
- 1100 W Class D Amplifier
- 60 x 60 constant directivity coverage angle
- 15" neo coaxial woofer, 3.5"v.c.
- 1.5" neo coaxial c. driver, 2.5"v.c.
- **FiRPHASE**
- RDNet remote monitoring and control
- Multifunctional cabinet
- Very high output

52

TT 052-A



ACTIVE ULTRA COMPACT HIGH OUTPUT SPEAKER

The TT 052-A is an extremely compact, active loudspeaker specifically designed for indoor applications where the audio beam must be directed towards specific zones. It is equipped with two 5" neodymium woofers and a 1" compression driver. Thanks to its constant directivity horn and high volume output, the TT 052-A can be used to guarantee the perfect intelligibility in critical environments.



DEDICATED PROCESSING

A dedicated processing area is available through the optional RDNet input board. Remote monitoring, special custom equalisations, high and low pass, single way solo and mute, and many other options. All available on RDNet.



FULLY FEATURED INPUT BOARD

TT 051-A and TT 052-A are equipped with a state of the art input board which features: XLR In/Out, Volume control, Eq. switch for wall mounting, Hi-pass filter switch, RDNet ready, RDNet bypass, 4 status LEDs, Powercon In/Out.



RENTAL PROOF

Combined with the AC TT051/52 pipe clamp, TT 051-A and TT 052-A are the perfect tools for the rental company. In a few seconds, the correct sound can be set in the desired direction.

The
**READERS'
CHOICE**
AWARDS 2013

WINNER



**RDNET
READY**

p.n. 130.00.245 (220-240V) - 130.00.246 (115V)

- 123 dB max SPL
- 300 W, 3 way amplification
- Heavy duty multi-functional cabinet
- 2 x 5" low distortion woofers
- 1" neodymium compression driver, 1.5" v. c.
- DSP processing
- Wall mount EQ, High pass EQ
- RDnet READY

51 TT 051-A

ACTIVE ULTRA COMPACT WIDE DISPERSION SPEAKER

The TT 051-A is an ultra compact, active loudspeaker designed specifically for high quality indoor nearfield sound amplification. It is equipped with a 300 W digital amplifier, 150 W for the low frequencies and 150 W for the high frequencies. A powerful 5" neodymium woofer and a 1" aluminium dome tweeter loaded to a wide dispersion constant directivity horn provide an extensive coverage.

POLE MOUNT READY

In association with the AC TT051/52 pole mount, TT 051-A and TT 052-A are easily combined with a subwoofer or pole mounted on a floor stand.



DEDICATED PROCESSING

A dedicated processing area is available through the optional RDNet input board. Remote monitoring, special custom equalisations, high and low pass, single way solo and mute, and many other options. All available on RDNet.



MODULAR MECHANICS

Special integrated side mechanics with a unique quick lock system have been developed to provide a fast and easy set up of the speakers, offering an outstanding application flexibility.



ROTATABLE LOGO

The TT 051-A and TT 052-A are equipped with rotatable logo to be used in vertical or horizontal position.



**RDNET
READY**

p.n. 130.00.243 (220-240V) - 130.00.244 (115V)

- 116 dB max SPL
- 300 W, 2 way amplification
- Heavy duty multi-functional cabinet
- 5" low distortion woofer
- 1" titanium dome tweeter
- DSP processing
- Wall mount EQ, High pass EQ
- RDnet READY

TT 08-A

ACTIVE TWO-WAY PRECISION MONITOR

The TT 08-A is the smallest and most powerful solution to almost any sound reinforcement situation. Hi-fi acoustic design, high quality neodymium transducers, powerful amplifiers, very compact size cabinet and incredibly lightweight. Superb deep bass punch, very linear and precise frequency response. The perfect solution for live sound situations, playback and monitoring.

The TT 08-A is by far the smallest member of the TT+ family, whilst being the most flexible and powerful tool in its class: from live sound to playback and monitoring, corporate events and broadcast studios. The TT 08-A offers an incredible maximum sound pressure level of 128 dB. Its performance efficiency is almost 3 dB higher than many larger 10" speaker systems and indeed comparable to many 12" systems.

Two different angles for near field or long field monitoring. Pole mount, fly bars, side M10 suspension points.

/ NEAR FIELD MONITORING

One side of the cabinet presents a 40° angle for near field monitoring applications.

OUTSTANDING POWER

Though remarkably compact and lightweight, the TT 08-A offers an incredible maximum SPL of 128 dB, making it suitable for use as either a single, primary loudspeaker or within multi cabinet horizontal and vertical arrays.

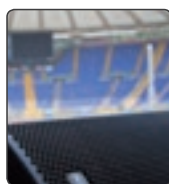

MAXIMUM FLEXIBILITY

The TT08-A is the perfect tool for broadcast monitoring, theatrical installations, front and side fills, under balcony coverage and distributed sound systems.



/ LONG FIELD MONITORING

The other side of the cabinet presents a 20° angle perfect for long field monitoring applications.



p.n. 130.00.116 (220-240V) - 130.00.120 (115V)

“ the smallest and most powerful solution ”

- 128 dB max SPL
- 750 W power digital switching amplifiers
- 90° x 60° constant directivity coverage angle
- 8" high power neodymium woofer, 2.5" v. c.
- 1" titanium compression driver, 1.7" v. c.
- High quality analog input board
- Soft limiter and RMS protection
- Baltic birch cabinet
- Maximum output per size on the market

56

TTS 56-A



ACTIVE HIGH POWER SUBWOOFER

The TTS 56-a is a high power, high output active subwoofer system that sets a new standard in the touring sound reinforcement. The new 21" neodymium design represents the result of many years dedicated in pioneering new solutions for transducer technology. The integration of the 6800 W, 2 channel digital amplification and the advanced digital processing set a new standard for distortion, noise and thermal efficiency.

The TTS 56-A amplifier section features 2 x 3400 W highly advanced digital amplifier modules. The power amplifiers and the input board are housed on a heavy duty aluminium paned suspended from the main cabinet with flexible mounts to obtain the best insulation from vibrations of the electronic parts.

EACH MODULE FEATURES

- Power Factor Correction (PFC)
- Separated power supply and amplification
- High efficiency, very low consumption
- Comprehensive, smart protection features: thermal, over-current, non audio signals
- Two "on board" ventilation fans

The input section provides a special switch to create a cardioid configuration when TTS 56-A subwoofers are used in groups of three.



THE NEW 21" TRANSDUCER DESIGN FEATURES

Very high force, neodymium magnet assembly 115 mm diameter, 33 mm length, inside-outside copper voice coil reinforced silicon double spiders carbon fiber doped water resistant cone heavy duty aluminum basket magnet assembly complex ventilation for minimum power compression.



INPUT BOARD

The input section provides:

- In/Out XLR connectors
- Crossover Out XLR connector
- System sensitivity control
- Crossover set-up (60 Hz - 90 Hz)
- High pass set-up (30 Hz - 45 Hz)
- 4 status LEDs
- RDnet Ethercon In/Out connectors



**RDNET
ON BOARD**

p.n. 130.00.190 (90-240V)



- 145 dB max SPL
- 6800 W(2 x 3400 W digital amplifiers)
- 2 x 21" high power neodymium woofers, 4.5" v. c.
- 96 kHz, 32 bit DSP processing
- Time delay alignment
- Cardioid preset for groups
- Tour grade Baltic birch cabinet
- Maximum output per size on market

36

TTS 36-A



ACTIVE HIGH POWER SUBWOOFER

The TTS 36-A is a high power, high output active subwoofer system that sets a new standard in the touring sound reinforcement. The new 18" neodymium design represent the result of many years dedicated in pioneering new solutions for transducer technology. The integration of the 4000 W, 2 channel digital amplification and the advanced digital processing set a new standard for distortion, noise and thermal efficiency.



INPUT BOARD

The input section provides:

- In/Out XLR connectors
- Crossover Out XLR connector
- System sensitivity control
- Crossover set-up (90 Hz - 120 Hz)
- High pass set-up (35 Hz - 50 Hz)
- 4 status LEDs
- RNet Ethercon In/Out connectors



**RNET
ON BOARD**

p.n. 130.00.272 (90-240V)

INSIDE VIEW

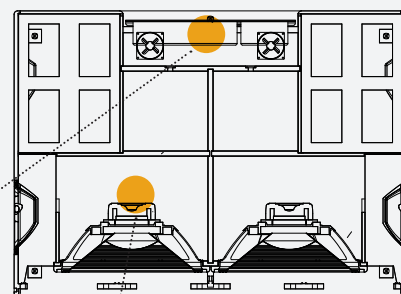

/ POWER PLATFORM

The power section comprises 2 x 2000 W digital amplifiers, a state of the art 32 bit floating point DSP processing, time delay setting, network board, high quality analog inputs.

/ BASS-REFLEX LOADING

The 2 x 18" woofers, in a separate chambers bass reflex configuration, provide a very tight and powerful extended bass response.



- 143 dB max SPL
- 4000 W (2 x 2000 W digital amplifiers)
- 2 x 18" high power neodymium woofers, 4.5" v. c.
- 96 kHz, 32 bit DSP processing
- RNet remote monitoring and control
- Time delay alignment
- Bass reflex design, Cardioid preset for groups
- Tour grade Baltic birch cabinet
- Maximum output per size

18

TTS 18-A II

ACTIVE HIGH POWER SUBWOOFER

The RCF TTS 18-A II is a compact, high output subwoofer system ideal in combination with TT+ two way systems. The RCF TTS 18-A II woofer features lightweight neodymium magnet, inside-outside copper voice coil; silicon double spiders; water resistant treated cone; magnet assembly complex ventilation for minimum power compression. The amplifier section features 1400 watt RMS SMPS class-D amplifier with full DSP and RDNet network capabilities.



APPLICATIONS

- Touring sound reinforcement for small and mid-sized venues
- Portable and installed audio-visual systems
- Theatres and night clubs
- Stage monitor, side fill and drum fill reinforcement
- DJ sound systems

INSIDE VIEW

/ HIGH PERFORMANCE HYPERVENTED WOOFER

RCF manufactures these components to deliver the cleanest, punchiest and undistorted low frequency reproduction. In order to dissipate the heat generated by the powerful 4.0" voice coil, RCF engineers have developed a unique ventilation system with very low power compression. The Hyper Ventilation System is the result of a complex combination of ventilation ducts in the voice coil former, in the magnetic structure and in the woofer's basket. In addition, a demodulation ring reduces the harmonic and intermodulation distortion associated with voice coil displacement and, as input current varies, the system inductances are more linear.



p.n. 130.00.545 (90-240V)



**RDNET
ON BOARD**

- 136 dB SPL Max
- 30-400 Hz Frequency Range
- 1 x 18" Hyper Vented Woofer, 4" Voice Coil
- DSP Controlled Input Section with selectable presets (e.g. cardioid)
- 1400W RMS Class-D Amplifier
- RDNet remote monitoring and control
- Vertical and horizontal placement with M20 pole receptacle on top and side

15

TTS 15-A

ACTIVE HIGH POWER SUBWOOFER

The RCF TTS 15-A is a compact, high output subwoofer module ideal in combination with TT+ two way touring systems. The RCF TTS 15-A features low weight for easy handling, weatherproof cabinet, a 15" woofer powered by a 1100 watt RMS SMPS class-D Amplifier with full DSP and RDNet network capabilities.



The Class-D 1100 W RMS SMPS amplifier is easily monitored and controlled from RDNet.



APPLICATIONS

- Touring sound reinforcement for small and mid-sized venues
- Portable and installed audio-visual systems
- Theatres and night clubs
- Stage monitor, side fill and drum fill reinforcement
- DJ sound systems

INSIDE VIEW

/ CABINET

The RCF TT+ cabinets are made of high-quality birch plywood with weatherproof treatment. The subs are stackable and light-weight, for an easy set-up and tear down. A pole receptacle on top and side allows the use of the woofer in various configurations. The polyurea coating and rugged structure of the cabinet have been designed to survive long-term use and transportation and the separate housing for the amplifier guarantees the best component efficiency and reliability.

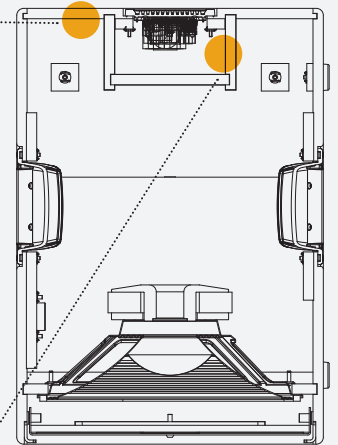

/ DSP PROCESSING

The fully featured DSP handles all the processing within the cabinet and allows control of soft clipping limiters, RMS limits, polarity, amplitude and equalization.

p.n. 130.00.543 (90-240V)



**RDNET
ON BOARD**

- 134 dB SPL Max
- 35-400 Hz Frequency Range
- 1 x 15" Woofer, 3.0" v.c.
- DSP Controlled Input Section with selectable presets (e.g. cardioid)
- 1100W RMS Class-D Amplifier
- RDNet remote monitoring and control
- Vertical and horizontal placement with M20 pole receptacle on top and side

1616

DX 1616

MATRIX AUDIO PROCESSOR

DX 1616 AES-Dante remote software. This network-based software designed for Microsoft Windows and Mac OSX allows the management of the DX 1616 Matrix Sound Processor.

- Pre-Amp configuration, selecting source types like analog, AES/EBU, Dante
- Designing Input groups for festival applications
- Input source processing with EQ, delay and compressor
- Powerful 16x16 router to assign processing tasks to flexible output patches.

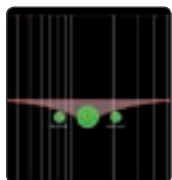

DSP MODULE

The DSP module offers high pass filters, low pass filters, parametric EQ, all pass filters, level, compressor and output delay for perfect system control even if no RDNet controlled speaker is part of the system.

p.n. 123.99.033



HOME

The home screen gives the most important information of the signal flow to the system engineer in one view. All inputs with pre-fade level meters including the routing to dedicated DSP modules for typical system tasks for main PA, side PA, subwoofer and distributed speakers. Useful groups of inputs allow easy setup and configuration for any large event application with several mixing desks or multiple sources.

SOURCE PROCESSING

The powerful source processing window allows the configuration of the input preamps (analog, AES/EBU, mic/line) and Dante inputs as well. For each source the user can adjust gain, polarity, input EQ, input compressor and input delay.

OUTPUT PATCH

Thanks to 16 analog outputs, DX 1616 offers flexible routing possibilities. The engineer can use up to 16 individual DSP modules for each output or he can even assign several analog outputs to a specific DSP module to use these outputs as high quality line drivers. In combination with the RCF CP16 control panel any demand of wiring the audio system is supported.

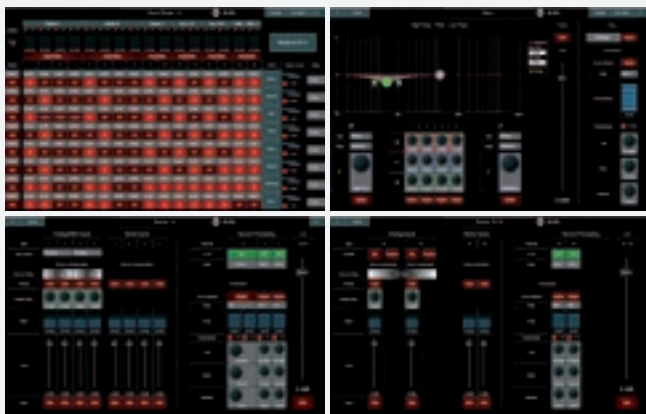

- Hybrid architecture DSP
- 48 kHz sampling, 40 bit floating point engine
- 16 x 16 I/O matrix
- Dante enabled network audio transport
- 8 AES/EBU inputs - 8 AES/EBU outputs
- Ethernet connectivity and control
- Maximum latency 3 ms
- Easy to use software GUI

16

CR 16-ND

CONTROL RACK

The CR 16-ND is a 10 Unit flight case designed to control RCF Professional speaker systems. The CR 16-ND includes one Control 8 that manages the RDNet connection to up to 256 devices, one DX 1616 matrix processor that takes care of audio signals routing and processing and one CP 16 control panel to bring audio and control signals to 4 x LK 25 multipin outputs. Each LK 25 has four audio channels, two RDNet channels and two spare sends. Each signal is doubled to XLR redundant outputs.



DIGITAL I/O

The DX 1616 matrix audio processor features Ethernet control, Dante redundant inputs, eight AES/EBU inputs and outputs. The signals are managed from a 40 bit floating point, high resolution DSP.

AUDIO AND CONTROL CENTER

With modern audio technologies, the sound system has to accept several source types such as analog signals, digital signals and even audio via network.

With the CR 16-ND RCF provides the perfect companion and control center. While RDNet takes care of the individual speaker or group of speakers, the DX 1616 matrix signal processor will manage up to 16 inputs - no matter if they come as analog signal, AES/EBU or even via Dante.

Thanks to a powerful DSP matrix, the engineer can assign each source to processing routines and flexible output patches. To ensure worldwide HDL 50-A system standards, the CP 16 control panel is part of the CR 16-ND control rack offering Ethercon sockets, XLR inputs and outputs, multi-pin outputs. Perfectly designed to match the RCF cabling solution.

Dual Switch Not Included.

Ask RCF and adapt the System to your networking protocol.



p.n. 121.00.004

- 10 RU flight case on shock mounts
- DX 1616 matrix audio processor
- Control 8 master unit
- CP16 control panel
- 16 analog audio inputs, 16 analog audio outputs
- 8 AES/EBU inputs - 8 AES/EBU outputs
- Dante input
- 4 x LK 25 multicore audio/RDNet outputs

PR 63

POWER RACK

The Power Rack PR 63 features the PD 63 A-419 power distribution with a 63 A Cekon power input with 5 m fixed cable. The three-phase power is distributed in a 32 A Cekon output, 4 x LKS19 output, 6 x Powercon output, 1 Powercon auxiliary output to power the CR 16-ND Control Rack. All outputs are equipped with individual RCBOs (Residual Current-operated Circuit-Breaker with Overcurrent protection) for maximum reliability. In case of damage, only the faulty output is missed while the rest of the system continues to function.



63-AMPERE RACK

From a single 63-Ampere Cekon connector the power rack delivers power distribution to large PA systems, including up to 12+12 left-right line array systems, a large subwoofer system and a complete stage monitoring. 32-Ampere power output for chain motors and 16-Ampere Powercon output to supply CR 16-ND are included.

In a sound reinforcement system, power has to be managed in a clever and safe way to ensure highest reliability and only by using high quality cables and sockets will it be touring proof. The LKS 19 power cable provides 6 x 20 A power feeds in a very tight pack. For additional speakers or even for the subwoofers close to the PR-63, the Powercon sockets can be used in parallel to the LKS 19 sockets.

LK 25 MULTIPIN

The LK 25 connectors feature easy-grip long and slim metal locking rings, aluminum back shells and skin tops with anti-bending spring. The studs are roller version to ensure easier coupling and a longer number of operations due to a lower wear and tear of coupling ramps. Each cable brings 4 audio channels, 2 RDNet control channels and 2 patchable spare lines. RCF offers a dedicated LK 25 fan out cable and two extension cables (10 m and 20 m).

SOLIDLY BUILT CABLES

RCF offers professional cables solidly built and easy to handle. All LK 25 and LKS 25 connections grant IP 67 protection and high strength for the intensive use and winding operations.



p.n. 121.00.006

- 63 Ampere Cekon power input with 5 m cable
- 32 Cekon outputs
- 4 x LKS 19 outputs
- 6 x Powercon outputs + 1 Powercon auxiliary output
- 24 x individual power line RCBOs
- 32 Ampere and Auxiliary individual front RCBOs
- Tour Grade flight case construction



Monitoring And Management Network

RDNet is a proprietary protocol for RCF products that provides straightforward and intuitive monitoring and control of the audio system down to every device/object. Each device has its own DSP, so it is possible to address specific presets or modifications of parameters to single or groups of objects. A network user can change level, delay, EQ (including FIR) and other parameters, including advanced subwoofer configurations. Not only loudspeakers: it is possible to control routing and parameters of multiple RCF devices, such as digital matrixes or amplifiers. RDNet checks all the connected devices, recognises, and adds them as objects on the main window, thanks to the auto-scan function. The real-time monitoring features a multitude of parameters such as fan speed, temperature, inclination of the single speaker, VU Meters and peak levels. The RDNet protocol runs on the ultra-stable RS-485 communication.



- Auto Scan
- Array and Zones Grouping
- Recall and Save System Presets
- Adjust gain and delay on individual components
- Complete Real Time Monitoring
- Real Time multiple-type EQ and FIRPHASE EQ
- Easy Cardioid, Endfire and Arc Array Subwoofer configuration
- Automatic Cluster Size shaping and Air Compensation

/ DOWNLOAD THE SOFTWARE



The RDNet software is freely available for registered users on RCF's website Download Section

/ AUTO SCAN

When online the RDNet Control 8 unit sequentially scans all audio devices, automatically labelling them with digital addresses. The loudspeaker objects are immediately added to the software synoptic as an object for each speaker (or any other audio device) found on the network.



MONITOR AND MANAGE

RDNNet checks all the connected devices, recognises and adds them as objects on the main window, thanks to the auto scan function. The real-time monitoring features a multitude of parameters like the fan speed, the temperature, the inclination of the single loudspeaker, VU Meters and peak levels.



ADVANCED EQUALIZER

Every Zone has three different fixed FIR equalisers with gain control. Every Array Group has a global control of the FirPhase Gain for parallel increment/decrement of the Zone FIRs.



GET THE MOST OF YOUR SYSTEM

An incremental control to shape the Air Absorption Compensation, very useful in case of humidity or temperature changes (e.g. soundcheck on a sunny day, concert by night). The low-mid shaping of the line array is an automatic calculation based on the Cluster Size to always obtain the perfect linear frequency response from the whole system.

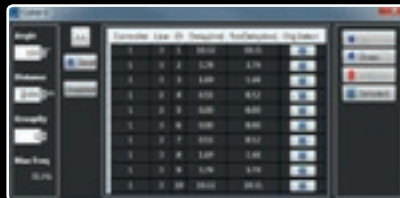

EASY SUBWOOFER CONFIGURATION

The new subwoofer configurations help the engineer to set up subwoofer Cardioids, Arcs or EndFire configurations in one go.

/ COMPLETE INDIVIDUAL SPEAKER CONTROL

The sound engineer has complete control of every single speaker, individually or grouped. Each device, with its own built-in communication board and DSP, is an active part of the brain of the system, able to store presets, receive commands and continuously send status information.

/ UNIQUE FEATURES

RDNNet has several new functions as well as multiple improvements. The protocol is now faster than ever, the new subwoofer configurations help the engineer to set up subwoofer cardioid, arcs or endfire configurations in one go. The real time EQ and the FirPHASE filters are now easy to control on the same window. An Air Compensation function automatically adjust the array response on temperature/humidity changes on the environment.

Control 8

8 OUTPUT MASTER UNIT

The RNet Control 8 is a real-time monitor and control system able to manage up to 256 devices linked 32 per bus in 8 buses. All data is collected from the slaves are delivered to the sound engineer by USB in a local installation or by Ethernet from remote locations. The interface can be directly connected to the DSP on board of HDL products through the exclusive RNet protocol making it possible to address single cabinets or groups, specific presets or modification parameters in real-time. The key point of RNet Control 8, in fact, is to ensure minimum refresh time (at least 5 per second) of all the system data performance like RMS signals, compressor activities, temperatures, fans speed and warnings.



COMMUNICATION FLEXIBILITY

The link between the PC and the RNet Control 8 unit can be made through USB port or Ethernet port.



TOPOLOGY FLEXIBILITY

The RNet Control 8 unit can manage up to 8 subnets. Up to 32 audio devices can be connected to each subnet (8 subnets x 32 = total 256 audio devices).



CONTROL FLEXIBILITY

The PC cyclically requires the RNet Control 8 unit the operating state of audio devices that make up the communication network. All data are collected by the central unit that performs a sequential scan of all audio devices. Digital address allocation is automatic. Information relating to the functioning of all audio devices is acquired in real-time, feature that allows a network global view. It is possible to check each single audio device and edit its parameters (e.g. output level, mute, equalization, delay, etc.) by using the PC software. The audio device overall configuration can be saved as file in the PC and later reloaded. It is possible to synchronize all parameter values of the RNet Control 8 unit to the ones of the PC software preset.



p.n. 171.70.154

- RNet control and monitoring in a single device by Ethernet or USB
- Up to 8 subnet of up to 32 slaves devices
- Automatic network configuration and registration
- Slave devices status and functions real time control
- Monitoring and display of faults and warnings
- User configurations storage and recall

“ control system able to manage up to 256 devices ”

Control 2



2 OUTPUT USB MASTER UNIT

The RDNet Control 2 is a hardware interface to connect RCF TT+ devices to a Personal Computer (PC) by means of an USB connection. The RDNet system was purposely developed to create a data network for monitoring and command of more systems. The RDNet Control 2 unit can manage up to 2 subnets. Up to 32 devices can be connected to each subnet (2 subnets x 32 = total 64 devices). The addressing of the various devices is handled automatically by RDNet Control 2 interface. Each device is assigned a unique address during the power on procedure of network.

We have developed a dedicated networking board for the latest TT+ products. Using our proprietary RDNet protocol it is possible to monitor all the system parameters, from the input to the status of each single amplifier. Having a Dsp on board each cabinet, it is possible to address single cabinets or groups of cabinets' specific presets or modifications of parameters like gain, equalisation or delay. The RDNet protocol is based on RS-485 communication protocol, it is very stable and it is possible to send and receive data on a simple XLR cable.



Address	Control	Use	Model	Gain	Subnet	Sample	Phase	Yr	Year	Equalizer	Gain	HP	Control	Send	Control	Range
1	1	1	1	1	1	1	1	1	1	1	1	1	1	1	1	1
2	2	2	2	2	2	2	2	2	2	2	2	2	2	2	2	2
3	3	3	3	3	3	3	3	3	3	3	3	3	3	3	3	3
4	4	4	4	4	4	4	4	4	4	4	4	4	4	4	4	4
5	5	5	5	5	5	5	5	5	5	5	5	5	5	5	5	5
6	6	6	6	6	6	6	6	6	6	6	6	6	6	6	6	6
7	7	7	7	7	7	7	7	7	7	7	7	7	7	7	7	7
8	8	8	8	8	8	8	8	8	8	8	8	8	8	8	8	8
9	9	9	9	9	9	9	9	9	9	9	9	9	9	9	9	9
10	10	10	10	10	10	10	10	10	10	10	10	10	10	10	10	10
11	11	11	11	11	11	11	11	11	11	11	11	11	11	11	11	11
12	12	12	12	12	12	12	12	12	12	12	12	12	12	12	12	12
13	13	13	13	13	13	13	13	13	13	13	13	13	13	13	13	13
14	14	14	14	14	14	14	14	14	14	14	14	14	14	14	14	14
15	15	15	15	15	15	15	15	15	15	15	15	15	15	15	15	15
16	16	16	16	16	16	16	16	16	16	16	16	16	16	16	16	16
17	17	17	17	17	17	17	17	17	17	17	17	17	17	17	17	17
18	18	18	18	18	18	18	18	18	18	18	18	18	18	18	18	18
19	19	19	19	19	19	19	19	19	19	19	19	19	19	19	19	19
20	20	20	20	20	20	20	20	20	20	20	20	20	20	20	20	20
21	21	21	21	21	21	21	21	21	21	21	21	21	21	21	21	21
22	22	22	22	22	22	22	22	22	22	22	22	22	22	22	22	22
23	23	23	23	23	23	23	23	23	23	23	23	23	23	23	23	23
24	24	24	24	24	24	24	24	24	24	24	24	24	24	24	24	24
25	25	25	25	25	25	25	25	25	25	25	25	25	25	25	25	25
26	26	26	26	26	26	26	26	26	26	26	26	26	26	26	26	26
27	27	27	27	27	27	27	27	27	27	27	27	27	27	27	27	27
28	28	28	28	28	28	28	28	28	28	28	28	28	28	28	28	28
29	29	29	29	29	29	29	29	29	29	29	29	29	29	29	29	29
30	30	30	30	30	30	30	30	30	30	30	30	30	30	30	30	30
31	31	31	31	31	31	31	31	31	31	31	31	31	31	31	31	31
32	32	32	32	32	32	32	32	32	32	32	32	32	32	32	32	32



p.n. 171.70.163 (USB POWERED)

- RDNet control and monitoring in a single device by USB communication
- Up to 2 subnet of up to 32 slaves devices
- Automatic network configuration and registration
- Slave devices status and functions real time control
- Monitoring and display of faults and warnings sent from slave devices
- User configurations storage and recall

“ full control from a pocket size device ”

PROJECTS AND CUSTOM DESIGNS

EASE DATA SOFTWARE

STATE OF THE ART FACTORY

RCF is an integrated designer and manufacturer, with the ability to provide top quality transducers or complete speaker systems, both passive and active, with integrated digital amplifier assemblies.

This characteristic is a major advantage in terms of product performance and competitiveness, since each time a new speaker cabinet is planned, the design of its transducer is carried-out simultaneously, in order to deliver uncompromised quality from the system.

PREDICTION SOFTWARE PACKAGE

In order to assist with the set up procedures for the TT+ Line Array Systems, RCF has developed a complete prediction software package. The software enables a complete two dimensional simulation of the behaviour of the cabinets arrays and also suggest the correct subwoofers combination. The system curvature angles and the sound projection data are computed with maximum sound pressure levels for the given design.

The rigging menu provides data for weight, centre of gravity and length of the array configuration. Rigging points and rigging hardware configurations are also computed.



SYSTEMS MODELING - EASE SIMULATIONS

An audio system design for environments like stadia, sports arenas, theatres, auditoriums, airports, places of worship -as well as concerts and live events- is often carried out taking into consideration the acoustics of the environment, the architectural and installation constraints, the maintenance costs and, on top of everything, the user's requirements. RCF R&D also has a dedicated automatic system for the high resolution measurements of the acoustical 'footprint' of the speakers, based on 360° balloon (i.e. GLL speaker data) required by EASE acoustic modelling software. This data is available both from the RCF website and the acoustic simulation software company.

ENGINEERING SUPPORT GROUP

The extensive range of RCF products enables the Engineering Support Group to submit multiple design solutions optimised and tailored according to budget and the requested performance spec. The design proposals are based on supplied venue details, including environmental acoustic simulation, product list, block diagram and speaker coverage mapping.

/ WEBSITE DOCUMENTATION

The RCF Website provides Manuals, Specsheets, Drawings, EASE data and GLL files, all available for download.

/ CUSTOM PRODUCTS AND MONITORING OPTIONS

All TT+ range of products is available with custom solutions to fulfil every system specification or requirements. Special optional control boards have been developed for various requirements like large systems real time monitoring, fault reports, GP inputs and outputs.

CABLING AND TRANSPORTATION



Besides the speaker design, the transportation and weather protection are an integral part of the system.

The TTL 55-A Kart allows four TTL 55-A speakers to be transported in vertical position.

All subwoofers are equipped with detachable front wheel boards, which makes the setup easy without having the rattling noise of wheels displayed towards the audience when using subs in cardioid setups.

RCF active sound reinforcement systems feature sophisticated weather protection to ensure a safe operation even under worse weather condition.

/ LKS 19 CONNECTORS

Thanks to the use of LKS 19 power distribution system with dedicated fan out cables it is possible to connect TTL 55-A, TTL 33-A II and companion subwoofers from a single 19 pin connector. One single cable run can power a full sized line array column. RCF offers dedicated fan out cables for arrays and subwoofers as well as extension cables of 10 m or 20 m.

/ DEDICATED ACCESSORIES

A full range of custom accessories complements the RCF line array systems. Starting from suspension and stacking to cabling and transportation, RCF provides solutions for a practical assembly, use and transportation from the smallest to the largest system.



ACCESSORIES

RIGGING



p.n. 133.60.120
FLY BAR TTL55

Suspending bar for TTL55-A line array system (including Pickup Point and Quick Lock pins).



p.n. 133.60.052
FLY BAR TTL33

Suspending bar for TTL33-A and TTL33-A II array systems.



p.n. 133.60.063
FLY BAR TTL33 SHORT

Short suspending bar for TTL33-A and TTL33-A II array system (including 2 Quick lock pins).



p.n. 133.60.131
LINK BAR TTL55-33-31

Transition Frame to connect up to 8 TTL33-A/TTL33-A II or TTL31-A/TTL31-A II under a TTL55-A line array system.



p.n. 133.60.154
LIFT KART TTL55

Lifting trolley for TTL55-A arrays.



p.n. 133.60.129
HOIST SPACING CHAIN TTL55

Hoist Connector Chain to distance the motor and the chain bag from the suspending bar keeping in vertical balance the system.



p.n. 133.60.128
SAFETY CHAIN TTL55

Safety chain for TTL55 array system.

RIGGING



p.n. 133.60.130
SHACKLE TTL55

3/4" Shackle ~ 4-3/4 tons for TTL55-A array system. To be added to the flybar accessory in case the pick up is made with 2 motors.



p.n. 133.60.127
FLY BAR PICKUP TTL55

Spare pickup point (including 2 quick lock pins).



p.n. 133.60.143
SHACKLE TTL33-TTL31

5/8" Shackle ~ for TTL33-A/TTL33-A II, TTL31-A/TTL31-A II array systems. To be added to the flybar accessory in case the pick up is made with 2 motors.



p.n. 133.60.349
FLY BAR TTL6-A

Flybar for TTL6-A and TTL6-AS.



p.n. 133.60.284
AC H-FLY BAR TTP5

TTP5-A horizontal fly bar.



p.n. 133.60.251
AC H-PLATE TTP5

TTP5-A horizontal installation plate.



p.n. 133.60.249
AC V-FLY BAR TTP5

TTP5-A vertical fly bar.

RIGGING



p.n. 133.60.252
AC H-BUMP TTP5

TTP5-A horizontal connecting bar.



p.n. 133.60.267
AC TT5 PLATE

2 X TT5-A installation plate.



p.n. 133.60.268
AC TT5 END PLATE

2 X TT5-A installation end-plate.



p.n. 133.60.265
AC TT5 H-BR

TT5-A horizontal U bracket with M10-PIN-pole mount.



p.n. 133.60.266
AC TT5 V-BR

TT5-A vertical U bracket with PIN.



p.n. 133.60.261
AC TT2 PLATE

2 X TT2-A installation plate.



p.n. 133.60.262
AC TT2 END PLATE

2 X TT2-A installation end-plate.

RIGGING



p.n. 133.60.259
AC TT2 H-BR

TT2-A horizontal U bracket with M10-PIN-pole mount.



p.n. 133.60.260
AC TT2 V-BR

TT2-A vertical U bracket with PIN.



p.n. 133.60.255
AC TT1 PLATE

2 X TT1-A installation plate.



p.n. 133.60.256
AC TT1 END PLATE

2 X TT1-A installation end-plate.



p.n. 133.60.253
AC TT1 H-BR

TT1-A horizontal U bracket with M10-PIN-pole mount.



p.n. 133.60.254
AC TT1 V-BR

TT1-A vertical U bracket with PIN.



p.n. 133.60.106
AC PRO8 V-BR

TT08 and TT08-A flying and wall mount bracket with mounting pole and adjustable inclination.

ACCESSORIES

RIGGING



p.n. 133.60.328
AC TT22 MKII V-BR

TT 22-A II wall mount brackets with adjustable inclination.



p.n. 133.60.329
AC TT25 MKII V-BR

TT 25-A II wall mount brackets with adjustable inclination.



p.n. 133.60.082
AC TT08 H-BR

Pair of horizontal bracket for mounting TT08 and TT08-A speakers on the wall.



p.n. 133.60.030
AC DS4X

Kit of 4 hooks for suspending fly track bar.



p.n. 133.60.342
AC TT051-52 L-BR

Vertical bracket for TT 051-A and TT 052-A.



p.n. 133.60.171
AC TT051/52 PIPE CLAMP

Pipe clamp adapter for TT051-A and TT052-A.



p.n. 133.60.172
AC TT051/52 STAND ADAPTER

Stand adapter for TT051-A and TT052-A.

STACKING



p.n. 133.60.057
STCK BAR TTL33

Accessory to add to Fly bar TTL33 for stacking option on sub. Quick lock pins to be added.



p.n. 133.60.110
AC PRO-PM

Pole mount with ring lock



p.n. 133.60.067
AC PM M20

M20 pole mount for TT22, TT22-A, TT25 and TT25-A speakers.



p.n. 133.60.034
AC PMA

Speaker pole mount.



p.n. 133.60.111
AC PRO-LF

Steel professional adapter sleeve for loudspeaker stands.



p.n. 133.60.109
AC PRO-FS

Steel speaker floor stand with folding base and telescopic rod. Tube diameter 35 mm. Load capacity up to 50 Kg.



p.n. 133.60.035
AC S260

Steel speaker floor stand with folding base and telescopic rod, tube diameter 35 mm. Equipped with damping system and safety plug; central die-cast joint.

STACKING



p.n. 133.60.068
AC TT PMA
Pole mount cap accessory.



p.n. 133.60.066
AC M20-PLATE
Threaded plate for M20 pole mount.

TRANSPORTATION



p.n. 133.60.121
KART 4X TTL55
Kart with wheels for 4 TTL55-A.



p.n. 133.60.133
AC WOOD KART TTL55
TTL55-A front kart.



p.n. 133.60.059
KART TTL33
Kart to transport 4 TTL33-A/TTL33-A II modules with the fly-bar connected.



p.n. 133.60.384
KRT-WH TTS 18 II
Kart to transport TTS 18-A II. Detachable front wheel board including 4 x 100 mm wheels.

TRANSPORTATION



p.n. 133.60.383
KRT-WH TTS 15
Kart to transport TTS 15-A. Detachable front wheel board including 4 x 100 mm wheels.



p.n. 133.60.248
AC WOOD KART TTP5
TTP5-A wood kart.



p.n. 133.60.140
FRONT WOOD COVER TTS56
Quick lock wood front protection for TTS56-A subwoofer. Compatible under the TTS56-A cover.

COVERS



p.n. 133.60.134
COVER TTL55
Single protection for one TTL55 array module. Includes a soft bag on top to store cables and spare pins. To be used in conjunction with TTL55-A single kart.



p.n. 133.60.135
COVER TTS56
Protection cover for one TTS56-A subwoofer. Best used in conjunction with TTL56-A front wood cover.



p.n. 133.60.396
CVR TTS 18 II
Cover for TTS 18-A II

ACCESSORIES

COVERS



p.n. 133.60.395
CVR TTS 15
Cover for TTS 15-A



p.n. 133.60.326
COVER TT 25-A II
Protection cover bag for TT 25-A II



p.n. 133.60.325
COVER TT 22-A II
Protection cover bag for TT 22-A II



p.n. 133.60.096
COVER TT08
Protection cover bag for TT08 and TT08-A.



p.n. 133.60.169
COVER TT051-A
Protection cover bag for TT051-A.



p.n. 133.60.170
COVER TT052-A
Protection cover bag for TT052-A.



p.n. 133.60.327
COVER TT 25-CXA
Protection cover bag for TT 25-CXA

COVERS



p.n. 133.60.250
AC COVER TTP5
TTP5-A cover.



p.n. 133.60.246
AC COVER TT5-A
TT5-A rain cover.



p.n. 133.60.245
AC COVER TT2-A
TT2-A rain cover.



p.n. 133.60.244
AC COVER TT1-A
Rain cover for TT1-A.



p.n. 133.60.157
AC SLED56
TTS56-A sub's hard nylon side reinforcements to facilitate ground transportation.

RAIN PROTECTIONS



p.n. 133.60.136
AC RAIN COVER TTL55
Rubber rain cover protection for TTL55-A amplifiers.

RAIN PROTECTIONS



p.n. 133.60.083
AC RAIN COVER TTL33

Rubber rain cover protection for TTL33-A and TTL33-A II amplifiers.



p.n. 133.60.137
AC RAIN COVER TTS56

Rubber rain cover protection for TTS56-A amplifiers.

CONTROL AND AUDIO CABLES



p.n. 133.60.226
AC RDNET INPUTS TTL33-A II

Accessory to convert TTL33-A input board to TTL33-A II.



p.n. 133.60.176
AC RD-NET IN-OUT PLUG

RDNNet control board for TTL11A, TT051-A and TT052-A.



p.n. 123.99.016
ETHERCON CABLE 0.6 M

Ethercon link cable 0.6 m to link HDL 50-A / HDL 53-AS.



p.n. 123.99.017
ETHERCON CABLE 1.5 M

Ethercon link cable 1.5 m to link SUB 900(6)7-AS.

CONTROL AND AUDIO CABLES



p.n. 123.99.035
ETHERCON CABLE 3 M

Ethercon link cable 3 m to link SUB 900(6)7-AS.



p.n. 123.99.018
ETHERCON CABLE 5 M

Ethercon link cable 5 m to link SUB 900(6)7-AS.



p.n. 123.99.019
ETHERCON TO XLR F ADAPTER 0.2 M

To adapts XLR female connector to RJ45 RDNNet socket on the speaker.



p.n. 123.99.020
ETHERCON TO XLR M ADAPTER 0.2 M

To adapts XLR male connector to RJ45 RDNNet socket on the speaker.



p.n. 123.99.021
LK 25-2 FAN OUT

LK 25 multipin cable fan out with LK 25 female connector and 8 x XLR male outputs. Length 2 m.



p.n. 123.99.023
LK 25-10 MULTIPIN

LK 25 male to female extension multi-pin cable. Length 10 m.



p.n. 123.99.022
LKS 25-20 MULTIPIN

LK 25 male to female extension multi-pin cable. Length 20 m.

ACCESSORIES

POWER DISTRIBUTION



p.n. 133.60.138
AC POWER CABLE 6X TTL55

AC Cable to power up to 6 TTL55-A or TTS56-A amplifiers.



p.n. 133.60.145
AC POWER BOX 6X TTL55

European stage box to power 6 TTL55-A line array modules.

USA p.n. 133.60.147



p.n. 123.99.025
LKS 19 SUB FAN OUT

LKS 19 male connector to 6x Neutrik Powercon.



p.n. 123.99.026
LKS 19 Break Out

LKS19 input to 6x Powercon outputs with Neutrik® weather protection. 1x LKS19 output.



p.n. 123.99.027
LKS 19-10 Power Cable

LKS 19 male to female extension power cable, length 10 m. Feeds 6 power lines.



p.n. 133.60.146
LKS 19-20 Power Cable

LKS 19 male to female extension power cable, length 20m. Feeds 6 power lines.



p.n. 123.99.031
Powercon Link 0.7 m

Powercon link cable 0.6 m to link HDL 50-A or HDL 53-AS.

POWER DISTRIBUTION



p.n. 123.99.030
Powercon Link 1.5 m

Powercon link cable 1.5 m to link SUB 900(6)7-AS to HDL 50-A or another subwoofer.



p.n. 123.99.029
Powercon Link 5 m

Powercon link cable 5 m to link SUB 900(6)7-AS to another subwoofer.



p.n. 123.99.028
Powercon Link 10 m

Powercon link cable 10 m to link distributed speakers.



p.n. 123.99.024
CABLES KIT LKS 19 ARRAY FAN OUT

Array fan out cable 0.5 - 1.3 - 2.1 - 2.9 - 3.7 - 4.5 M

QUICK LOACKS PINS



p.n. 133.60.132
AC 4PIN FLY BAR TTL55

4X pin set.
Spare set in case original pins are damaged or lost.

PRODUCT	POSITION	TPOLOGY
FL-B TTL 55	FRONT	LINK
FL-B LINK TTL 55-33-31	FRONT	LINK



p.n. 133.60.219
AC 4 PIN HDL 20 FRONT

4X pin set.
Spare set in case original pins are damaged or lost.

PRODUCT	POSITION	TPOLOGY
TTL 6-A	REAR	LINK
TTL 6-AS	REAR	LINK
V-BR TT 1	SIDE	LOCK
V-BR TT 2	SIDE	LOCK
V-BR TT 5	SIDE	LOCK
V-BR TT 22 II	SIDE	LOCK
V-BR TT 25 II	SIDE	LOCK



p.n. 133.60.122
AC 4PIN TTL55

4X pin set.
Spare set in case original pins are damaged or lost.

PRODUCT	POSITION	TPOLOGY
TTL 55-A	FRONT	LINK
TTL 55-A	REAR	LINK
TTL 55-A	FRONT	LOCK
TTL 36-AS	FRONT	LINK
TTL 36-AS	FRONT	LOCK
TTL 36-AS	REAR	LINK

QUICK LOACKS PINS



p.n. 133.60.222
AC 4 PIN HDL 20 FRAME

4X pin set.
Spare set in case original pins are damaged or lost.

PRODUCT	POSITION	TPOLOGY
TTL 6-A	FRONT	LINK
TTL 6-AS	FRONT	LINK
FL-B TTL 6	FRONT	LOCK
FL-B TTL 6	REAR	LINK



p.n. 133.60.060
AC 4PIN TTL33

4 quick lock pins kit for TTL33-A array system.



p.n. 133.60.077
AC 4PIN TTL31 NXL23

4 quick lock pins for TTL31-A and NXL23-A array system.

TECHNICAL SPECIFICATIONS

ACTIVE SPEAKERS

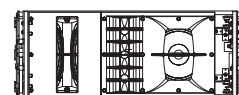
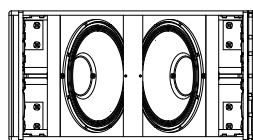
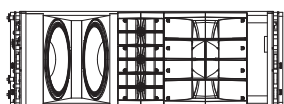

TTL 55-A



RDNET ON BOARD

p.n. 130.00.188 (220-240V)
p.n. 130.00.189 (115V)

ACOUSTICAL SPEC.

Frequency Response	50 Hz - 20 kHz
Max SPL	143 dB
Horizontal coverage angle	90°
Vertical coverage angle	max 7°
Compression Driver	3 x 1.5" neo, 2.5" v.c.
Midrange	10" neo, 3.5" v.c.
Woofer	2 x 12" neo, 4" v.c.

INPUT SECTION

Input connector	xlr, RDNet Ethercon
Output connector	xlr, RDNet Ethercon
Input sensitivity	4 dBu

PROCESSOR SECTION

Crossover frequencies	320 Hz - 1300 Hz
Protections	thermal, excurs., rms
Limiter	soft limiter
Controls	Dsp controlled

AMPLIFIER

Total power (RMS)	3500 Watt
High frequencies (RMS)	500 Watt
Mid frequency (RMS)	1000 Watt
Low frequencies (RMS)	2 x 1000 Watt
Cooling	convection/forced
Connection	powercon

PHYSICAL SPEC.

Height	380 mm (15")
Width	1020 mm (40")
Depth	550 mm (21.6")
Weight	67 Kg (147.7 lbs)
Cabinet	baltic birch plywood
Hardware	array fly-ware
Handles	2 side

TTL 36-AS



RDNET ON BOARD

p.n. 130.00.271 (90-240V)

Frequency Response	35 Hz - 120 kHz
Max SPL	142 dB
Horizontal coverage angle	-
Vertical coverage angle	-
Compression Driver	-
Midrange	-
Woofer	2 x 18" neo, 4.5" v.c.

Input connector	xlr, RDNet Ethercon
Output connector	xlr, RDNet Ethercon
Input sensitivity	-2 dBu / + 10 dBu

Crossover frequencies	60 Hz - 90 Hz selectable
Protections	thermal, excurs., rms
Limiter	soft limiter
Controls	Dsp controlled

Total power (RMS)	-
High frequencies (RMS)	-
Mid frequency (RMS)	-
Low frequencies (RMS)	2 x 2000 Watt
Cooling	convection/forced
Connection	powercon

Height	536 mm (21.10")
Width	1022 mm (40.23")
Depth	970 mm (38.18")
Weight	120 Kg (264.55 lbs)
Cabinet	baltic birch plywood
Hardware	array fly-ware
Handles	6 side

TTL 33-A II



RDNET ON BOARD

p.n. 130.00.360 (220-240V)
p.n. 130.00.361 (115V)

Frequency Response	60 Hz - 20 kHz
Max SPL	135 dB
Horizontal coverage angle	100°
Vertical coverage angle	max 15°
Compression Driver	3 x 1.0" neo, 1.5" v.c.
Midrange	8" neo, 2.5" v.c.
Woofer	2 x 8" neo, 2.5" v.c.

Input connector	xlr, RDNet Ethercon
Output connector	xlr, RDNet Ethercon
Input sensitivity	-2 dBu / + 4 dBu

Crossover frequencies	400 Hz - 1800 Hz
Protections	thermal, hf
Limiter	rms, fast limiter
Controls	hf correction, cluster size, HPF

Total power (RMS)	1250 Watt
High frequencies (RMS)	250 Watt
Mid frequency (RMS)	500 Watt
Low frequencies (RMS)	500 Watt
Cooling	convection/forced
Connection	powercon

Height	300 mm (11.8")
Width	760 mm (30.0")
Depth	450 mm (18.2")
Weight	32,5 Kg (71.5 lbs)
Cabinet	baltic birch plywood
Hardware	array fly-ware
Handles	2 side

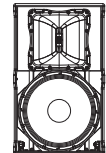
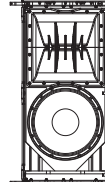

TTL 6-A

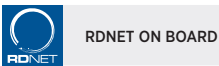

p.n. 130.00.475 (220-240V)
p.n. 130.00.476 (115V)

45 Hz - 20 kHz
139 dB
90°
30°
1.4" neo, 3.0" v.c.
4 x 6.0" neo, 2.0" v.c.
2 x 12" neo, 3.0" v.c.

xlr, RDNet Ethercon
xlr, RDNet Ethercon
+ 4 dBu

200, 800 Hz
thermal, rms
soft limiter
Near, Mid, Far, 2x Presets

2200 Watt
400 Watt
700 Watt
1100 Watt
convection
powercon

1100 mm (43.31")
378 mm (14.88")
468 mm (18.42")
53 Kg (116.84 lbs)
baltic birch plywood
Pole mount, integrated
2 side

TTL 6-AS

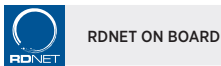

p.n. 130.00.500 (90-240V)

35 Hz - 400 Hz
139 dB
-
-
-
3 x 12" neo, 3.0" v.c.

xlr, RDNet Ethercon
xlr, RDNet Ethercon
+ 4 dBu

selectable
thermal, rms
soft limiter
High pass, Low pass Presets

-
-
-
1650 Watt
convection
powercon

1100 mm (43.31")
378 mm (14.88")
468 mm (18.42")
45 Kg (99.20 lbs)
baltic birch plywood
Pole mount, integrated
2 side

TTP 5-A



p.n. 130.00.380 (220-240V)
p.n. 130.00.384 (115V)

45 Hz - 20 kHz
138 dB
22.5°
60°
2" neo, 4.0" v.c.
-
15" neo, 4.0" v.c.

xlr, RDNet On Board
xlr, RDNet On Board
+ 4 dBu

550 Hz
thermal, rms
soft lim., dynamic proces.

1600 Watt
500 Watt
-
1100 Watt
convection
Powercon in-out

986 mm (38.81")
458 mm (18.03")
646 mm (25.43")
66,0 Kg (145.50 lbs)
baltic birch plywood
Cluster mechanics
2 side, 1 top, 1 bottom

TT 5-A



p.n. 130.00.379 (220-240V)
p.n. 130.00.383 (115V)

45 Hz - 20 Hz
136 dB
90°
50°
2" neo, 4.0" v.c.
-
15" neo, 4.0" v.c.

xlr, RDNet ready
xlr, RDNet ready
+ 4 dBu

650 Hz
thermal, rms
soft limiter, dynamic proces.

1600 Watt
500 Watt
-
1100 Watt
convection
Powercon in-out

735 mm (28.94")
443.8 mm (17.47")
529 mm (20.82")
42,0 Kg (92.59 lbs)
baltic birch plywood
Instal./rental fittings
2 side

TECHNICAL SPECIFICATIONS

ACTIVE SPEAKERS

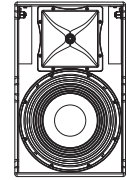
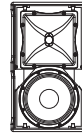

TT 2-A



RDNET READY

p.n. 130.00.378 (220-240V)
p.n. 130.00.382 (115V)

ACOUSTICAL SPEC.

Frequency Response	50 Hz - 20 kHz
Max SPL	134 dB
Horizontal coverage angle	90°
Vertical coverage angle	50°
Compression Driver	2" neo, 3.0" v.c.
Midrange	-
Woofer	12" neo, 4.0" v.c.

INPUT SECTION

Input connector	xlr, RDNet ready
Output connector	xlr, RDNet ready
Input sensitivity	+ 4 dBu

PROCESSOR SECTION

Crossover frequencies	750 Hz
Protections	thermal, rms
Limiter	soft limiter, dynamic proces.
Controls	

AMPLIFIER

Total power (RMS)	1600 Watt
High frequencies (RMS)	500 Watt
Mid frequency (RMS)	-
Low frequencies (RMS)	1100 Watt
Cooling	convection
Connection	Powercon in-out

PHYSICAL SPEC.

Height	643 mm (25.31")
Width	372 mm (14.64")
Depth	470 mm (18.50")
Weight	34,0 Kg (74.95 lbs)
Cabinet	baltic birch plywood
Hardware	Instal./rental fittings
Handles	2 side

TT 1-A



RDNET READY

p.n. 130.00.377 (220-240V)
p.n. 130.00.381 (115V)

Frequency Response	55 Hz - 20 kHz
Max SPL	131 dB
Horizontal coverage angle	90°
Vertical coverage angle	60°
Compression Driver	2" neo, 3.0" v.c.
Midrange	-
Woofer	10" neo, 3.0" v.c.

Input connector	xlr, RDNet ready
Output connector	xlr, RDNet ready
Input sensitivity	+ 4 dBu

Crossover frequencies	900 Hz
Protections	thermal, rms
Limiter	soft limiter, dynamic proces.

Total power (RMS)	800 Watt
High frequencies (RMS)	250 Watt
Mid frequency (RMS)	-
Low frequencies (RMS)	550 Watt
Cooling	convection
Connection	Powercon in-out

Height	566 mm (22.28")
Width	333 mm (13.11")
Depth	370 mm (14.56")
Weight	25,4 Kg (55.99 lbs)
Cabinet	baltic birch plywood
Hardware	Instal./rental fittings
Handles	2 side

TT 25-A II



RDNET ON BOARD

p.n. 130.00.446 (220-240V)
p.n. 130.00.447 (115V)

Frequency Response	50 Hz - 20 kHz
Max SPL	134 dB
Horizontal coverage angle	90°
Vertical coverage angle	60°
Compression Driver	1.5" neo, 4.0" v.c.
Midrange	-
Woofer	15" neo, 3.5" v.c.

Input connector	xlr, RDNet on-board
Output connector	xlr, RDNet on-board
Input sensitivity	+ 4 dBu

Crossover frequencies	750 Hz
Protections	thermal, HF
Limiter	fast limiter, dynamic proces.
Controls	8 selectable presets

Total power (RMS)	1100 Watt
High frequencies (RMS)	300 Watt
Mid frequency (RMS)	-
Low frequencies (RMS)	800 Watt
Cooling	convection
Connection	Powercon in-out

Height	670 mm (26.38")
Width	425 mm (16.73")
Depth	425 mm (16.73")
Weight	29,1 Kg (64.15 lbs)
Cabinet	Polyurea coated Baltic birch
Hardware	6 Fly tracks, q. lock, p. mount
Handles	2 side

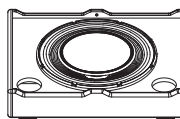
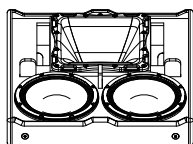
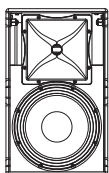

TT 22-A II

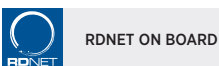

p.n. 130.00.444 (220-240V)
p.n. 130.00.445 (115V)

50 Hz - 20 kHz

131 dB

90°

60°

1.5" neo, 3.0" v.c.

-

12" neo, 3.5" v.c.

xlr, RDNet on-board

xlr, RDNet on-board

+ 4 dBu

800 Hz

thermal, HF

fast limiter, dynamic proces.

8 selectable presets

1100 Watt

300 Watt

-

800 Watt

convection

Powercon in-out

600 mm (23.62")

365 mm (14.37")

379 mm (14.92")

18,5 Kg (40.79 lbs)

Polyurea coated Baltic birch

6 Fly tracks, q. lock, p. mount

2 side

TT 45-CXA

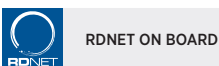

p.n. 130.00.506 (220-240V)
p.n. 130.00.507 (115V)

45 Hz - 20 Hz

136 dB

50°

90°

1.5" neo, 4.0" v.c.

-

2 x 10" neo, 3.0" v.c.

xlr, RDNet on-board

xlr, RDNet on-board

+ 4 dBu

600 Hz

thermal, HF

soft limiter, dyn. proces.

8 selectable presets

2200 Watt

1100 Watt

-

1100 Watt

convection

Powercon in-out

420 mm (16.53")

575 mm (22.64")

628 mm (24.72")

30 Kg (66.13 lbs)

Polyurea coated B. birch

pole m., 4 x Quicklock

1 side, 1 back

TT 25-CXA



p.n. 130.00.448 (220-240V)
p.n. 130.00.449 (115V)

50 Hz - 20 Hz

136 dB

60°

60°

1.5" neo, 2.5" v.c.

-

15" neo, 3.5" v.c.

xlr, RDNet on-board

xlr, RDNet on-board

+ 4 dBu

900 Hz

thermal, HF

soft limiter, dyn. proces.

8 selectable presets

1100 Watt

300 Watt

-

800 Watt

convection

Powercon in-out

352,9 mm (13.89")

580 mm (22.83")

486,5 mm (19.15")

18,0 Kg (39.6 lbs)

Polyurea coated B. birch

pole mount

1 top

TT 052-A



p.n. 130.00.245 (220-240V)
p.n. 130.00.246 (115V)

65 Hz - 20 kHz

123 dB

Conical 90°

Conical 90°

1 x 1" neo, 1.5" v.c.

-

2 x 5" woofer, 1.2" v.c.

xlr, RDNet ready

xlr

-2 dBu / + 10 dBu

1500 Hz

thermal, excurs., rms

soft limiter

Dsp controlled

300 Watt

150 Watt

-

150 Watt

convection

powercon

493 mm (19.40")

150 mm (5.90")

190 mm (7.48")

9,5 Kg (20.94 lbs)

baltic birch plywood

multi-functional

Top, bottom

TECHNICAL SPECIFICATIONS

ACTIVE SPEAKERS

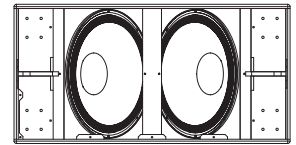

TT 051-A



RDNET READY

p.n. 130.00.243 (220-240V)
p.n. 130.00.244 (115V)

ACOUSTICAL SPEC.

Frequency Response	65 Hz - 20 kHz
Max SPL	116 dB
Horizontal coverage angle	Conical 110°
Vertical coverage angle	Conical 110°
Compression Driver	1 x 1" metal tweeter
Midrange	-
Woofers	1 x 5" woofer, 1.2" v.c.

INPUT SECTION

Input connector	xlr, RDNet ready
Output connector	xlr
Input sensitivity	-2 dBu / + 10 dBu

PROCESSOR SECTION

Crossover frequencies	1800 Hz
Protections	thermal, excurs., rms
Limiter	soft limiter
Controls	Dsp controlled

AMPLIFIER

Total power (RMS)	300 Watt
High frequencies (RMS)	150 Watt
Mid frequency (RMS)	-
Low frequencies (RMS)	150 Watt
Cooling	convection
Connection	powercon

PHYSICAL SPEC.

Height	348 mm (13.70")
Width	150 mm (5.90")
Depth	190 mm (7.48")
Weight	7 Kg (15,43 lbs)
Cabinet	baltic birch plywood
Hardware	multi-functional
Handles	Top, bottom

TT 08-A

p.n. 130.00.116 (220-240V)
p.n. 130.00.120 (115V)

Frequency Response	65 Hz - 20 kHz
Max SPL	128 dB
Horizontal coverage angle	90°
Vertical coverage angle	60°
Compression Driver	1" neo, 1.75" v.c.
Midrange	-
Woofers	8" neo, 2.5" v.c.

Input connector	xlr
Output connector	xlr
Input sensitivity	-2 dBu / + 4 dBu

Crossover frequencies	1700 Hz
Protections	thermal, hf
Limiter	rms, soft limiter
Controls	side/floor coupling

Total power (RMS)	750 Watt
High frequencies (RMS)	250 Watt
Mid frequency (RMS)	-
Low frequencies (RMS)	500 Watt
Cooling	convection
Connection	powercon

Height	430 mm (16.93")
Width	270 mm (10.63")
Depth	303 mm (11.93")
Weight	11,4 Kg (25.13 lbs)
Cabinet	baltic birch plywood
Hardware	2 Fly tracks, p. mount
Handles	-

TTS 56-A



RDNET ON BOARD

p.n. 130.00.190 (90-240V)

Frequency Response	30 Hz - 100 Hz
Max SPL	145 dB
Horizontal coverage angle	-
Vertical coverage angle	-
Compression Driver	-
Midrange	-
Woofers	2 x 21" neo, 4.5" v.c.

Input connector	xlr, RDNet Ethercon
Output connector	xlr, RDNet Ethercon
Input sensitivity	-2 dBu / + 10 dBu

Crossover frequencies	60 Hz - 80 Hz
Protections	thermal, excurs., rms
Limiter	soft limiter
Controls	Dsp controlled

Total power (RMS)	6800 Watt
High frequencies (RMS)	-
Mid frequency (RMS)	-
Low frequencies (RMS)	2 x 3400 Watt
Cooling	convection/forced
Connection	powercon

Height	590 mm (23.22")
Width	1170 mm (46.06")
Depth	988 mm (38.89")
Weight	115 Kg (253.5 lbs)
Cabinet	baltic birch plywood
Hardware	Steel bars x fork-lift, 4 wheels
Handles	6 side

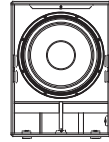
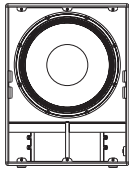
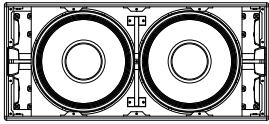

TTS 36-A



RDNET ON BOARD

p.n. 130.00.272 (90-240V)

35 Hz - 120 Hz

143 dB

-

-

-

-

2 x 18" neo, 4.5" v.c.

xlr, RDNet Ethercon

xlr, RDNet Ethercon

-2 dBu / + 10 dBu

80 Hz - 120 Hz

thermal, excurs., rms

soft limiter

Dsp controlled

4000 Watt

-

-

2 x 2000 Watt

convection/forced

powercon

525 mm (20.66")

1170 mm (46.06")

850 mm (33.46")

95 Kg (209.4 lbs)

baltic birch plywood

Steel bars x fork-lift, 4 wheels

6 side

TTS 18-A II



RDNET ON BOARD

p.n. 130.00.545 (90-240V)

30 Hz - 400 Hz

137 dB

-

-

-

-

18" neo, 4" v.c.

xlr, RDNet on-board

xlr, RDNet on-board

+ 4 dBu

50 Hz - 100 Hz selectable

thermal, excurs., rms

fast limiter

Dsp controlled

2800 Watt

-

-

2800 Watt

convection/forced

powercon

708 mm (27.87")

540 mm (21.26")

732 mm (28.82")

56.8 Kg (125.22 lbs)

baltic birch plywood

array fly-ware

2 side

TTS 15-A



RDNET ON BOARD

p.n. 130.00.543 (90-240V)

40 Hz - 400 Hz

134 dB

-

-

-

-

15" neo, 3" v.c.

xlr, RDNet on-board

xlr, RDNet on-board

+ 4 dBu

60 Hz - 400 Hz selectable

thermal, excurs., rms

fast limiter

Dsp controlled

2200 Watt

-

-

2200 Watt

convection/forced

powercon

600 mm (23.62")

445 mm (17.52")

633 mm (24.92")

41.3 Kg (91.05 lbs)

baltic birch plywood

array fly-ware

2 side



www.rcf.it

HEADQUARTERS:

RCF S.p.A. Italy
tel. +39 0522 274 411
e-mail: info@rcf.it

RCF UK
Int. +44 (0) 1702 800846
e-mail: info@rcfaudio.co.uk

RCF France
tel. +33 1 49 01 02 31
e-mail: france@rcf.it

RCF Germany
tel. +49 2203 925370
e-mail: germany@rcf.it

RCF Spain
tel. +34 91 817 42 66
e-mail: info@rcfaudio.es

RCF Benelux
tel. +49 (0) 2203 9253724
e-mail: benelux@rcf.it

RCF USA Inc.
tel. +1 732-9026100
e-mail: info@rcf-usa.com