

DRAWMER

SP2120

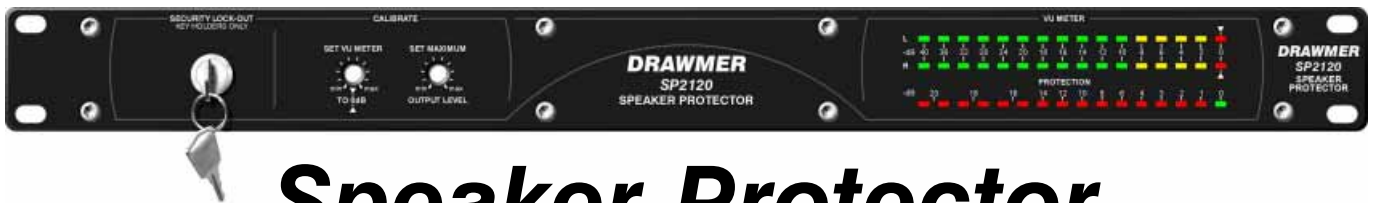

Speaker Protector

CONTENTS

Warranty	2
Safety Consideration	2
<i>Chapter 1 - Introduction</i>	
Introduction	3
Installation	4
Audio Connections	4
Installation and Connection Guide - Stereo Pair	5
Installation and Connection Guide - Multiple Speakers	6
<i>Chapter 2 - Control Description</i>	
Front Panel Controls	7
The Setup Procedure	7
<i>Chapter 3 - General Information</i>	
If a fault develops	8
Contacting Drawmer	8
Specification	9
Block Diagram	9

COPYRIGHT

This manual is copyrighted © 2003 by Drawmer Electronics Ltd. With all rights reserved. Under copyright laws, no part of this publication may be reproduced, transmitted, stored in a retrieval system or translated into any language in any form by any means, mechanical, optical, electronic, recording, or otherwise, without the written permission of Drawmer Electronics Ltd.

ONE YEAR LIMITED WARRANTY

Drawmer Electronics Ltd., warrants the Drawmer SP2120 Speaker Protector to conform substantially to the specifications of this manual for a period of one year from the original date of purchase when used in accordance with the specifications detailed in this manual. In the case of a valid warranty claim, your sole and exclusive remedy and Drawmer's entire liability under any theory of liability will be to, at Drawmer's discretion, repair or replace the product without charge, or, if not possible, to refund the purchase price to you. This warranty is not transferable. It applies only to the original purchaser of the product.

For warranty service please call your local Drawmer dealer. Alternatively call Drawmer Electronics Ltd. at +44 (0)1709 527574. Then ship the defective product, with transportation and insurance charges pre-paid, to Drawmer Electronics Ltd., Coleman Street, Parkgate, Rotherham, S62 6EL UK. Write the RA number in large letters in a prominent position on the shipping box. Enclose your name, address, telephone number, copy of the original sales invoice and a detailed description of the problem. Drawmer will not accept responsibility for loss or damage during transit.

This warranty is void if the product has been damaged by misuse, modification or unauthorised repair.

THIS WARRANTY IS IN LIEU OF ALL WARRANTIES, WHETHER ORAL OR WRITTEN, EXPRESSED, IMPLIED OR STATUTORY. DRAWMER MAKES NO OTHER WARRANTY EITHER EXPRESS OR IMPLIED, INCLUDING, WITHOUT LIMITATION, ANY IMPLIED WARRANTIES OF MERCHANTABILITY, FITNESS FOR A PARTICULAR PURPOSE, OR NON-INFRINGEMENT. PURCHASER'S SOLE AND EXCLUSIVE REMEDY UNDER THIS WARRANTY SHALL BE REPAIR OR REPLACEMENT AS SPECIFIED HEREIN.

IN NO EVENT WILL DRAWMER ELECTRONICS LTD. BE LIABLE FOR ANY DIRECT, INDIRECT, SPECIAL, INCIDENTAL OR CONSEQUENTIAL DAMAGES RESULTING FROM ANY DEFECT IN THE PRODUCT, INCLUDING LOST PROFITS, DAMAGE TO PROPERTY, AND, TO THE EXTENT PERMITTED BY LAW, DAMAGE FOR PERSONAL INJURY, EVEN IF DRAWMER HAS BEEN ADVISED OF THE POSSIBILITY OF SUCH DAMAGES.

Some states and specific countries do not allow the exclusion of implied warranties or limitations on how long an implied warranty may last, so the above limitations may not apply to you. This warranty gives you specific legal rights. You may have additional rights that vary from state to state, and country to country.

DRAWMER

SP2120-1

SPEAKER PROTECTOR

SAFETY CONSIDERATIONS

CAUTION - MAINS FUSE

TO REDUCE THE RISK OF FIRE
REPLACE THE MAINS FUSE ONLY WITH
A FUSE THAT **CONFORMS TO IEC127-2.**
250 VOLT WORKING, TIME DELAY TYPE
AND BODY SIZE OF 20mm x 5mm.
THE MAINS INPUT FUSE MUST
BE RATED AT T200mA.

CAUTION - MAINS CABLE

DO NOT ATTEMPT TO CHANGE
OR TAMPER WITH THE
SUPPLIED MAINS CABLE.

CAUTION - SERVICING

DO NOT PERFORM ANY SERVICING.
REFER ALL SERVICING TO QUALIFIED
SERVICE PERSONNEL.

WARNING

TO REDUCE THE RISK OF FIRE OR
ELECTRIC SHOCK DO NOT EXPOSE
THIS EQUIPMENT TO RAIN OR MOISTURE.



In the interests of product development, Drawmer reserve the right to modify or improve specifications of this product at any time, without prior notice.

DRAWMER DMS-1 SP2120 SPEAKER PROTECTOR



INTRODUCTION

The Drawmer SP2120 Speaker Protector offers both strict level control and tremendous peace of mind to the contractor, installer and venue in the knowledge that, as its name suggests, the 1U, two channel processor eliminates the possibility of 'unauthorised' excessive sound pressure levels on speaker systems (as caused by spikes and pops in the system, or by over-enthusiast dj's/engineers) which

could result in damage to both chassis drivers and amplifier electronics. In addition only the maintenance engineer and the venue manager hold a key. The unit also gives a wide variety of venues, such as clubs, theatres, pubs, schools, universities etc. the opportunity to comply with the local legislation regarding noise levels.

The key features are as follows:

- Key Holder access only
- Takes only minutes to install
- Dual 16 segment Left/Right bargraphs for 'at a glance' level metering
- 'Protection' processing 16 segment bargraph display
- No sound quality loss even during heavy protection processing
- Once installed and calibrated completely eliminates the possibility of 'unauthorised' volume levels
- Eliminates sound system abuse and the resulting cost of chassis speaker re-cones, HF diaphragm replacements and amplifier repairs.
- Reduces 'call-out' costs of sound system service/repair engineers
- Reduces sound system 'down time' and the consequential loss of venue income
- Isolation transformer output option.

The SP2120 front panel features an integral security lock to ensure that adjustments to maximum volume levels are implemented by key holders only. In 'unlocked' mode two front panel pre-sets are exposed and available for adjustment by the installer. The first calibrates the 16 segment Left/Right bargraphs to the incoming audio and dictates the point at which 'protection' processing commences. The second sets the absolute volume level to which the sound system is allowed to perform. If the SP2120 receives increased signal levels, the transparent 'protection' circuitry is activated which maintains the specified system volume level without degradation in sound quality.

The SP2120 greatly benefits from Drawmer's 25 years experience in designing industry standard dynamic processing devices. Its signal path combines a mixture of 'multiple time constant' circuitry and automatic gain control (AGC) which allow small overloads to sound louder – even though they're not.

Its concept and development was encouraged by Drawmer distributors and installers dissatisfied with other protection systems currently available. These often take the form of a crude switch, either turning off the power or disconnecting the speakers, both of which are 'disruptive' in any event.

INSTALLATION

The SP2120 Speaker Protector is designed for standard 19" rack mounting and occupies 1U of rack space. Where possible, avoid mounting the unit directly above power amplifiers or power supplies that radiate significant amounts of heat.

If the unit is to be used in a mobile situation, it is strongly recommended that the rear of the unit is supported in the carrying rack to avoid bending the front panel rack mounting 'ears'. Use fibre or plastic washers to prevent the front panel becoming marked by the mounting bolts. Always connect the mains earth to the unit.

Drawmer have gone to great lengths to make the Speaker Protector tamper-proof by incorporating the locking mechanism on the front, however, if the rear of the unit, along with the power amplifier, were reconnected, by an engineer/dj trying to gain more level, then the protection system would effectively be bypassed. For this reason it is imperative that both the SP2120 and the power amp be locked in a rack, where access to the rear is very difficult.

Fig. 1 shows the ideal connection setup, providing the greatest protection for your system. Note the position of the SP2120 along the audio chain - it should be connected directly before the amplifier that is supplying the speakers, (or before the active speakers), with the amplifier volume set to maximum. If the SP2120 were to be connected earlier in the chain, prior to the pre-amp/mixer for example, then it would be possible to add gain, sending noise levels higher than required.

The SP2120 can be used in a configuration where a stereo output is distributed around several speakers. Fig.3 shows a setup where the signal is distributed into six pairs using a Drawmer DA6, whilst still providing speaker protection for all twelve speakers. Again, note the position of the SP2120's along the audio chain - they should all be connected directly before the amplifier that is supplying the speakers (or active speakers), with the amplifier volume set to maximum.

AUDIO CONNECTIONS

The inputs and outputs are electronically balanced XLRs where pin 1 is screen, pin 2 hot, pin 3 cold and the XLR shell is connected to chassis. The operating level is nominally +4dBu. Balanced use is recommended.

- Interference:

If the unit is to be used where it maybe exposed to high levels of disturbance such as found close to a TV or radio transmitter, we advise that the unit is operated in a balanced configuration. The screens of the signal cables should be connected to the chassis connection on the XLR connector as opposed to connecting to pin1. The SP2120 conforms to the EMC standards.

- Ground Loops:

If ground loop problems are encountered, never disconnect the mains earth, but instead, try disconnecting the signal screen on one end of each of the cables connecting the outputs of the SP2120 to the patchbay. If such measures are necessary, balanced operation is recommended.

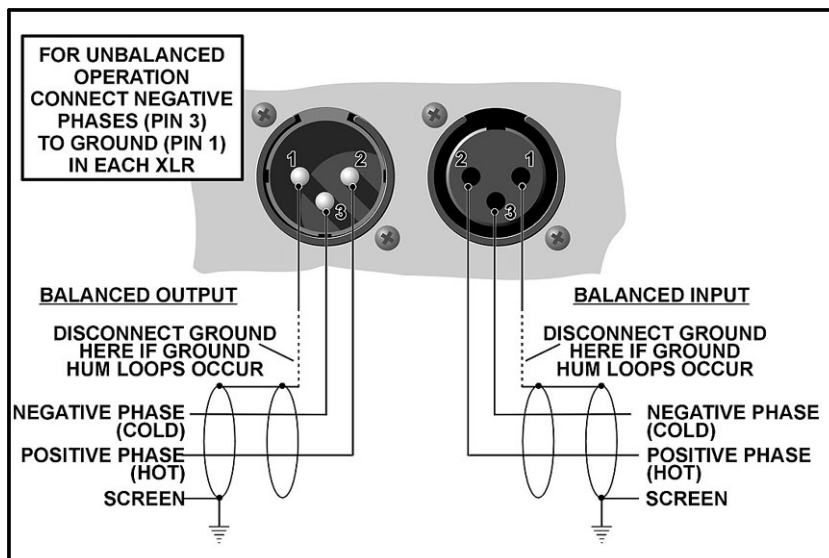

fig.1 XLR WIRING

fig.2 INSTALLATION AND CONNECTION GUIDE - Stereo Pair

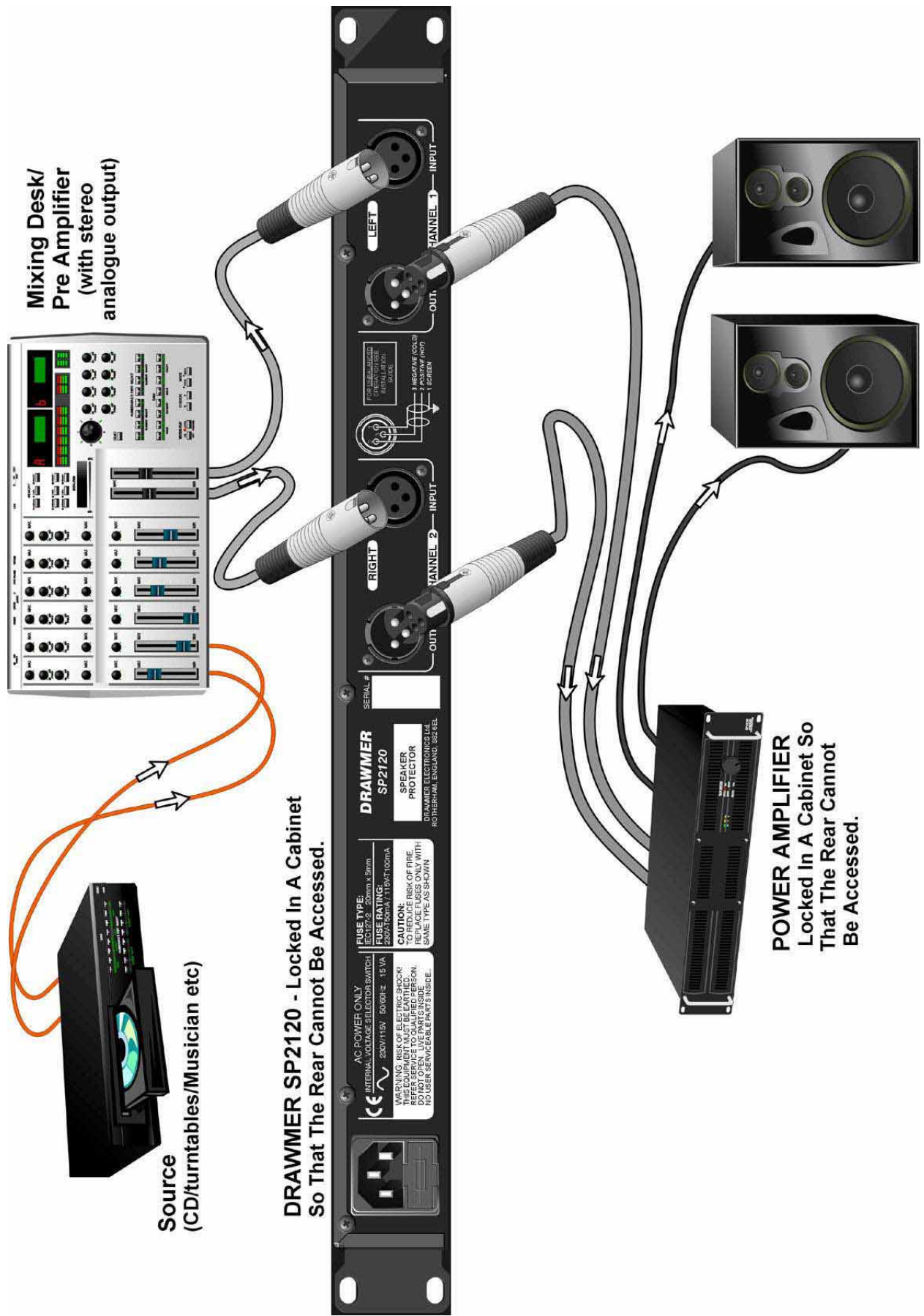
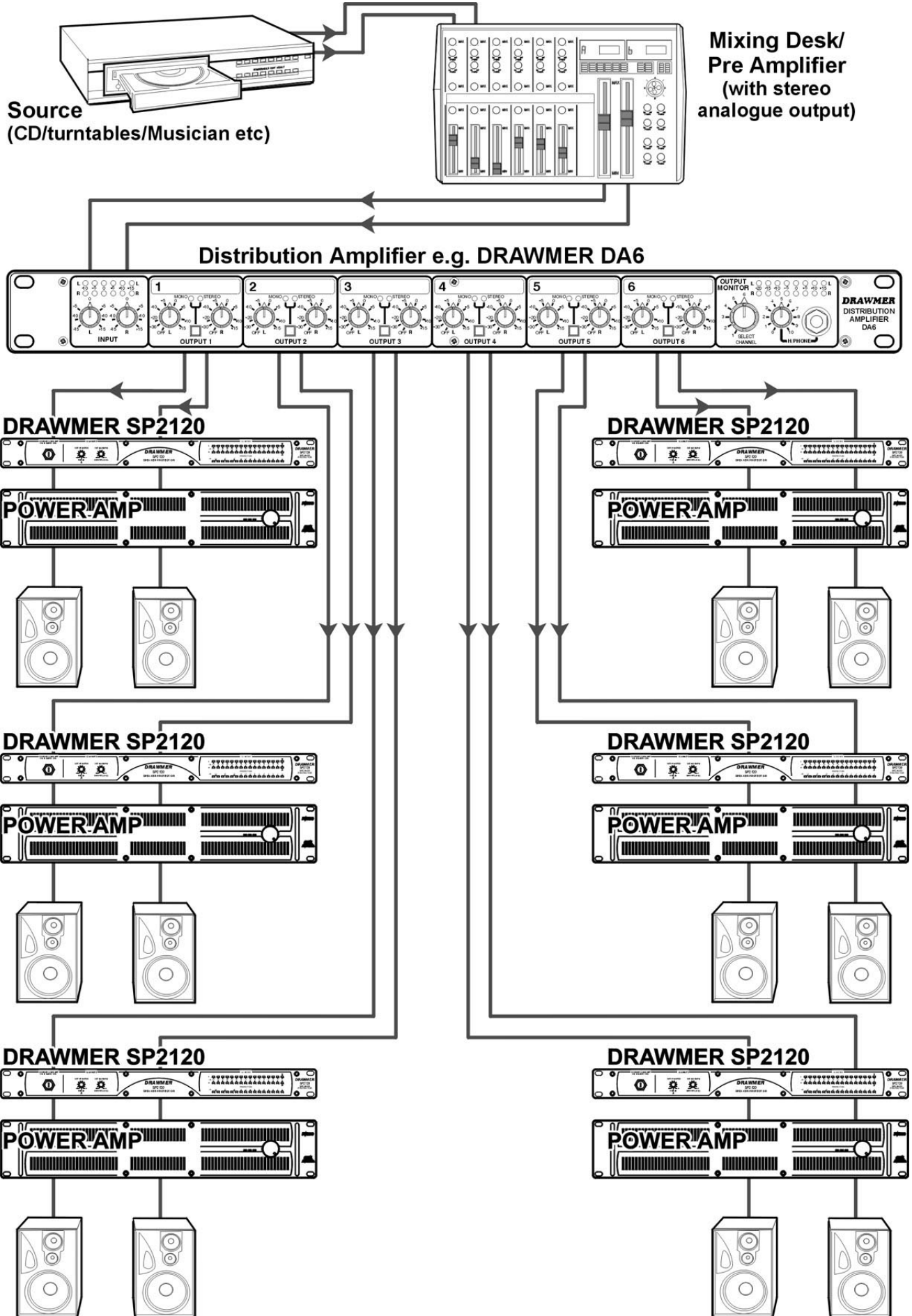
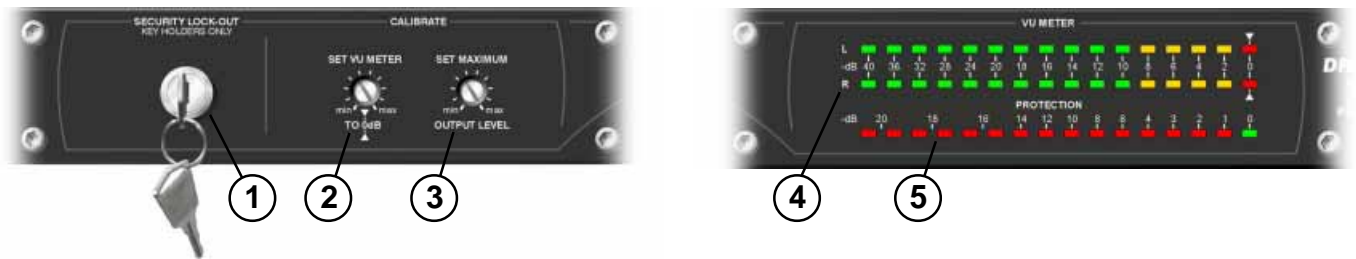

fig.3 INSTALLATION AND CONNECTION GUIDE - Multiple Speakers



CONTROL DESCRIPTION



- ① **SECURITY LOCK-OUT** A lock prevents access to the front panel controls of the SP2120 once it has been calibrated. Unlock, calibrate, lock again. Only authorised personnel should be supplied with a key.
- ② **CALIBRATE SET VU METER TO 0dB** With the unit unlocked, rotate using a screwdriver to adjust the level of signal to the vu meters. The general rule is to adjust the level so that the meters reach 0dB only on signal peaks.
- ③ **SET MAXIMUM OUTPUT LEVEL** With the unit unlocked, rotate using a screwdriver to adjust the level of signal supplied to the amplifier.
- ④ **VU METER** Two 16 LED, left and right bargraph meters provides a visual indication of the levels to adjust the “Set VU meter to 0dB” control.
- ⑤ **PROTECTION METER** A 16 LED bargraph meter provides a visual indication of the amount of protection that is being carried out by the SP2120. The higher the protection meter reads the more the SP2120 is having to work to keep the levels of sound within the set parameters - set the controls so that this meter illuminates as little as possible.

THE SETUP PROCEDURE

Use the following procedure to setup your system. In a configuration where a stereo output is distributed around several speakers, such as in fig.3, then the setup procedure should be used for each speaker pair.

- a. Ensure that the system is connected correctly and that both the SP2120 and the amplifier that follows it are locked in a cabinet where access is limited.
 - b. Using the key provided unlock the front ① to provide access the the calibration controls.
 - c. Using a small screwdriver turn the calibrate controls “Set VU Meter to 0dB” ② and “Set Maximum Output Level” ③ fully anti-clockwise to the min position.
 - d. Turn the level on the power amp to its maximum gain level.
 - e. Playing a load piece of music, that will provide high input levels to the SP2120, rotate the “Set VU Meter to 0dB” control ② until the L/R VU meters ④ reach 0dB on signal peaks, and no more than the first two leds of the protection meter ⑤ are lit.
 - f. Adjust the “Set Maximum Output Level” control ③ until the noise levels from the power amp reaches a level as set by the local authority, or the maximum level that can be tolerated (whichever is lowest) - in this way even if the input levels are increased, by an engineer applying gain on the mixing desk for example, this noise level will never be exceeded.
 - g. Lock the unit and remove the key ①.
 - h. Lock the cabinet that the SP2120 and amplifier are in.
- Test the system by increasing gain from the mixing desk (or anywhere preceding the SP2120 in the audio chain) - as you increase the level the protection meter ⑤ should increase but the overall signal level of the system will remain within the set parameters.

GENERAL INFORMATION

IF A FAULT DEVELOPS

For warranty service please call Drawmer Electronics Ltd. or their nearest authorised service facility, giving full details of the difficulty.

A list of all main dealers can be found on the Drawmer webpages.

On receipt of this information, service or shipping instructions will be forwarded to you.

No equipment should be returned under the warranty without prior consent from Drawmer or their authorised representative.

For service claims under the warranty agreement a service Returns Authorisation (RA) number will be issued. Write this RA number in large letters in a prominent position on the shipping box. Enclose your name, address, telephone number, copy of the original sales invoice and a detailed description of the problem.

Authorised returns should be prepaid and must be insured.

All Drawmer products are packaged in specially designed containers for protection. If the unit is to be returned, the original container must be used. If this container is not available, then the equipment should be packaged in substantial shock-proof material, capable of withstanding the handling for the transit.

CONTACTING DRAWMER

Drawmer Electronics Ltd., will be pleased to answer all application questions to enhance your usage of this equipment. Please address correspondence to:

Drawmer (Technical Help line)
Coleman Street
Parkgate
Rotherham
S62 6EL
UK

Alternatively contact us by E-mail on :

tech@drawmer.com

Further information on all Drawmer dealers, Authorised service departments and other contact information can be obtained from our web pages on:

<http://www.drawmer.com>

SP2120 SPEAKER PROTECTOR DATA SPECIFICATION

INPUT

Input Impedance	20k Ohms
Max Input level	+21dBu
CMR	>40dB (22Hz-22kHz)

OUTPUT

Output Impedance	100 Ohms
Output Level	Variable. Infinity to +14dBu
Balance	>40dB (22Hz-22kHz)

Isolating Transformers can be fitted in Output stage.

Crosstalk	> 90dB at 20k Hz
Noise	-103dB (Unity gain ref +4dBu / 22Hz-22kHz)
Power Requirements	115Volt or 230Volt at 50-60Hz, 9VA

BLOCK DIAGRAM

